

## I .Description:

D1-Series Potato Peeler is the new product developed and designed with the imported advanced foreign technology. It is suitable for the round or oval vegetable and fruits such as ginger, carrot, potatoes cleaning and peeling. It is with the fine appearance, easy to operate and clean, high efficiency, low consumption and long using life. The barrel and the body of the machine are made of good stainless steel, not rust, it can meet the health standards. It is supplied with filter system, can be more environmental friendly.

## II .Technical parameter:

Model	Power (KW)	Volt (V)	Freq (Hz)	Capacity (L)	Dimension mm	Weight (kg)
X6D1	0.37	230	50	6	570x335x690	30
X10D1	0.55	230	50	10	615x410x725	44
X15D1	0.75	230	50	15	645x435x785	50

## III .Maintenance and notes:

1. Before use, please check that the power supply corresponds to that required by the machine, and that the external earth wire is reliable connected.
2. Put the machine on the horizontal ground.
3. Link to the drain pipe (prepare by yourself), and close the discharge door.
4. Put the potatoes into the bowl, and add water to rinse at the same time.
5. Connect with the power supply and press the start button, and then cut off the electricity and water after reaching the expected standards.
6. Open the discharge door, and take out potatoes.
7. Open the upper cover and the idler wheel, then wash the barrel after work.
8. The inner of this Potato Peeler is the dismantlable sheet, it is more easy for maintenance and clean.

## IV NOTE:

1. DO NOT PUT HANDS OR OTHER THINGS INTO THE BOWL IN ORDER TO AVOID INJURY OR MACHINE DAMAGED.
2. The motor of the machine has the overload protection devices. The motor will be stopped automatically when the potato peeler is overload or blocked. The motor thermal protection switch will reset when the motor is cooled enough.
3. The drainpipe is blocked if there is no waste water and dregs or less waste water and dregs out from the drainpipe when the machine operate properly. To clean up the drainpipe.
4. If the supply cord is damaged, it must be replaced by the manufacturer or its service agent or a similarly qualified person in order to avoid a hazard.
5. This appliance is not intended for use by persons (including children) with reduced physical, sensory or mental capabilities, or lack of experience and knowledge, unless they have been given supervision or instruction concerning use of the appliance by a person responsible for their safety.
6. Children should be supervised to ensure that they DO NOT play with the appliance.
7. The appliance is not to be cleaned with a water jet.
8. Cleaning the potato peeler in a correct way.



## V . Circuit Diagram

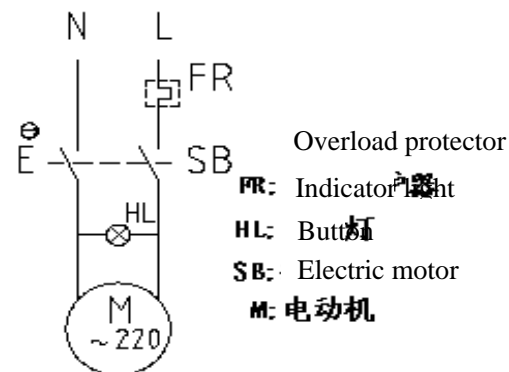

#### IV. Explosive Draw

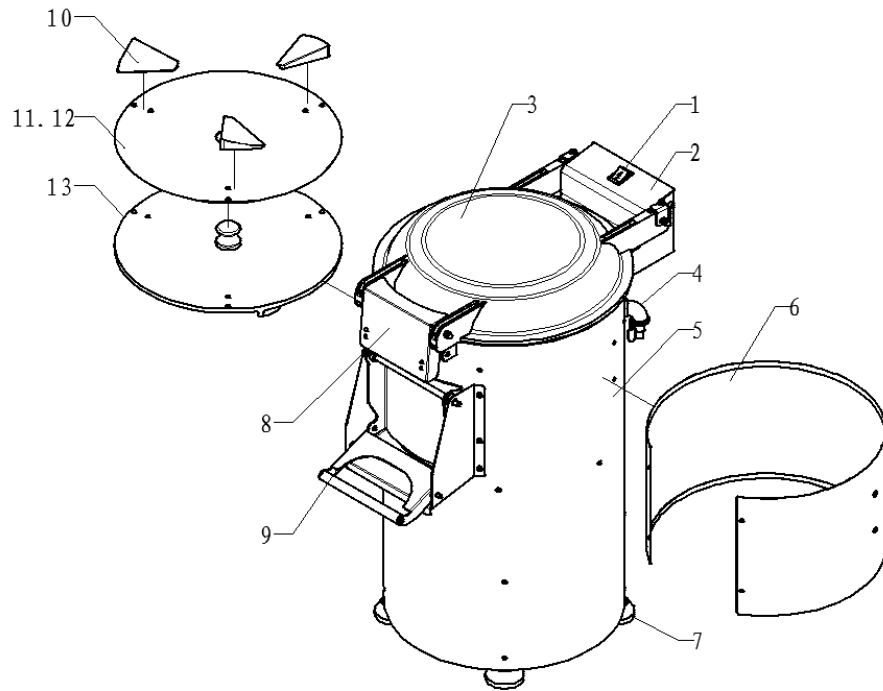

- |               |              |                    |                      |
|---------------|--------------|--------------------|----------------------|
| 1.Switch      | 2.Switch Box | 3.Cover            | 4.Water Inlet        |
| 5.Barrel      | 6.Sandpaper  | 7.D60 Nylon Foot   | 8.Handle             |
| 9.Outlet Door | 10.Upender   | 11.Wheel Sandpaper | 12.Double-sided tape |
| 13.Wheel      |              |                    |                      |

Imported by: Adexa Direct Limited

Unit 1 Swift Point, Cosford Lane, Swift Valley Industrial Estate, Rugby,  
CV21 1QN, UK

service@adexa.co.uk , T:+44 1788 222 410



# Adexa

## D1-Series Potato Peeler

### User's Manual

X6D1 X10D1 X15D1

