USER MANUAL



1	Operating Manual	4
1.1	General	4
1.2	Information on this manual	4
1.3	Warning notices	4
1.4	Limitation of liability.....	5
2	Safety	5
2.1	Intended use	5
2.2	General Safety information.....	6
2.3	Sources of danger	7
2.3.1	Risk of fire / flammable materials used. Danger of burns or of explosion.....	7
2.3.2	Dangers due to electrical power.....	8
3	Commissioning	8
3.1	Safety information	8
3.2	Unpacking	9
3.3	Disposal of the packaging	9
3.4	Setup	10
3.4.1	Setup location requirements:.....	10
3.4.2	Feet.....	10
3.5	The handle installing	11
3.6	Electrical connection	11
4	Design and Function	11
4.1	Complete overview.....	12
4.1.1	Removal of stainless steel shelves	12
5	Operation and Handling	13
5.1	Operating elements and displays	13
5.2	Rating plate.....	15
6	Dry ageing	15
6.1	Safety information	15
6.2	Exemption from liability:.....	15
6.3	Information about dry ageing.....	15
7	Cleaning and Maintenance	16
7.1	Safety information	16
7.2	Changing the UV lamp	18

7.3	Moving the appliance	19
8	Troubleshooting	19
8.1	Safety notices	20
8.2	Fault indications and rectification of faults	20
9	Disposal of the Old Device	21

1 Operating Manual

1.1 General

Please read the information contained herein so that you can become familiar with your device quickly and take advantage of the full scope of its functions.

Your device will serve you for many years if you handle it and care for it properly. We wish you a lot of pleasure in using it!

1.2 Information on this manual

These Operating Instructions are a component and provide you with important information for the initial commissioning, safety, intended use and care of the device.

The Operating Instructions must be available at all times at the device. This Operating Manual must be read and applied by every person who is instructed to work with the device:

- Commissioning
- Operation
- Troubleshooting and/or

- Cleaning

Keep the Operating Manual in a safe place and pass it on to the subsequent owner along with the device.

1.3 Warning notices

The following warning notices are used in the Operating Manual concerned here.

▲GEFAHR

DANGER

A warning notice of this level of danger indicates a potentially dangerous situation.

If the dangerous situation is not avoided, this can lead to death or serious injuries.

► Observe the instructions in this warning notice in order to avoid the danger of death or serious personal injuries.

▲WARNUNG

WARNING

A warning notice of this level of danger indicates a possible dangerous situation.

If the dangerous situation is not avoided, this can lead to serious injuries.

► Observe the instructions in this warning notice in order to avoid the personal injuries.

▲VORSICHT

ATTENTION

A warning notice of this level of danger indicates a possible dangerous situation.

If the dangerous situation is not avoided, this can lead to slight or moderate injuries.

► Observe the instructions in this warning notice in order to avoid the personal injuries.

HINWEIS

PLEASE NOTE

A notice of this kind indicates additional information, which will simplify the handling of the machine.

1.4 Limitation of liability

All the technical information, data and notices with regard to the installation, operation and care are completely up-to-date at the time of printing and are compiled to the best of our knowledge and belief, taking our past experience and findings into consideration.

No claims can be derived from the information provided, the illustrations or descriptions in this manual. The manufacturer does not assume any liability for damages arising as a result of the following:

- Non-observance of the manual
- Uses for non-intended purposes
- Improper repairs
- Technical alterations, modifications of the device
- Use of unauthorized spare parts

Modifications of the device are not recommended and are not covered by the guarantee. All translations are carried out to the best of our knowledge. We do not assume any liability for translation errors, not even if the translation was carried out by us or on our instructions.

13 Safety

This chapter provides you with important safety notices when handling the device. The device corresponds with the required safety regulations. Improper use can result in personal or property damages.

2.1 Intended use

This device is only intended for use in enclosed spaces for the storage and ageing of meat (beef, pork and poultry etc). The equipment is not suitable for fish.

Uses for a different purpose or for a purpose which exceeds this description are considered incompatible with the intended or designated use.

▲WARNING WARNING

Danger due to unintended use! Dangers can emanate from the device if it is used for an unintended use and/or a different kind of use.

- ▶ Use the device exclusively for its intended use.
- ▶ Observe the procedural methods described in this Operating Manual.

Claims of all kinds due to damages resulting from unintended uses are excluded.

The User bears the sole risk.

2.2 General Safety information

HINWEIS

PLEASE NOTE

Please observe the following general safety notices with regard to the safe handling of the device.

- ▶ Examine the device for any visible external damages prior to using it. Never put a damaged device into operation.
- ▶ If the power cable or plug are damaged, then they must be replaced by the manufacturer or its service agent in order to avoid a hazard.
- ▶ This device must not be used by children. The appliance and its connecting cable must be kept away from children.
- ▶ Children shall not play with the appliance.
- ▶ Cleaning and user maintenance shall not be made by children.
- ▶ The appliance may be used by individuals with reduced physical, sensory or mental capabilities or a lack of experience and / or knowledge of their use if they are supervised or have been instructed at to the safe use of the appliance and have understood the resulting hazards. Cleaning and user maintenance shall not be made by children.
- ▶ Do not leave the device unsupervised when it is in operation.
- ▶ The equipment is not a refrigerator. Do not use the equipment to store foods other than those mentioned under "Intended use".
- ▶ The equipment is not suitable for the smoking of meat.
- ▶ Only customer service departments authorized by the manufacturer may carry out repairs on the device, as otherwise the guarantee entitlements will be null and void in the event of any subsequent damages. Improperly performed repairs can cause considerable dangers for the user.

- ▶ Defective components must always be replaced with original replacement parts. Only such parts will guarantee that the safety requirements are fulfilled.
- ▶ The device actively regulates the desired humidity. Do not use salt blocks for regulation of humidity in the device. The device could be damaged. If, nevertheless salt blocks are used, the guarantee of the device expires. The manufacturer assumes no guarantee for damages of device or meat.

2.3 Sources of danger

2.3.1 Risk of fire / flammable materials used. Danger of burns or of explosion

There is a danger of burns and explosion due to excess pressure that is created in the event the device is not used properly.

Observe the following safety notices to avoid dangers of burns or an an explosion:



Warning: Risk of fire / flammable materials used.

- ▶ Do not store explosive substances such as aerosol cans with a flammable propellant in this device.
- ▶ Blowing gas inside the unit is flammable.
- ▶ Do not damage the cooling circuit of the device.
- ▶ Do not use electrical devices inside the device.
- ▶ Do not use mechanical devices to accelerate the defrosting process.
- ▶ Never use the device to store or dry flammable materials.
- ▶ Never clean appliance parts with flammable fluids. The fumes can create a fire hazard or explosion.

▲GEFAHR**DANGER**

- ▶ Do not store or use gasoline or any other flammable vapours and liquids in the vicinity of this or any other appliance. The fumes can create a fire hazard or explosion.

2.3.2 Dangers due to electrical power

▲GEFAHR

Mortal danger due to electrical power!

Mortal danger exists when coming into contact with live wires or subassemblies!

Observe the following safety notices to avoid dangers due to electrical power:

- ▶ Before changing the inner light, turn off the appliance first and then unplug the unit from the wall outlet.
- ▶ Do not operate this device if it has a damaged cable or plug, if it is not working properly or if it has been damaged or dropped. If the power cable or plug are damaged, then they must be replaced by the manufacturer or its service agent in order to avoid a hazard.
- ▶ Do not open the housing on the device under any circumstances. There is a danger of an electrical shock if live connections are touched and the electrical or mechanical structure is altered. In addition, functional faults on the device can also occur.

3 Commissioning

This chapter provides you with important safety notices during the initial commissioning of the device. Observe the following notices to avoid dangers and damages:

3.1 Safety information

▲WARNING**WARNING**

- ▶ Packaging materials may not be used for playing. There is a danger of suffocation.
- ▶ Transport, unpack and use two persons to set down the device because of the heavy weight of the device.

3.2 Unpacking

To unpack the device, proceed as follows:

- Remove the device out of the carton and remove the packaging material.
- The device should only be moved in an upright position.
- Clean the interior surface with lukewarm water using a soft cloth.
- After at least 24 hours, plugging the appliance into the wall outlet, than place meat in the appliance.

3.3 Disposal of the packaging

The packaging protects the device against damages during transit. The packaging materials are selected in accordance with environmentally compatible and recycling-related points of view and can therefore be recycled. Returning the packaging back to the material loop saves raw materials and reduces the quantities of accumulated waste.

Take any packaging materials that are no longer required to “Green Dot” recycling collection points for disposal.

HINWEIS

PLEASE NOTE



- ▶ If possible, keep the original packaging for the device for the duration of the guarantee period of the device, in order that the device can be re-packaged properly in the event of a guarantee claim.

3.4 Setup

3.4.1 Setup location requirements:

In order to ensure the safe and trouble-free operation of the device, the setup location must fulfil the following prerequisites:

- Place your appliance on a floor that is strong enough to support the appliance when it is fully loaded.
- Locate the appliance away from direct sunlight and sources of heat (stove, heater, radiator, etc.). Direct sunlight may affect the acrylic coating and heat sources may increase electrical consumption.
- This unit is not designed for use in a garage or any other outside installation.
- Do not set up the device in a hot, wet or extremely damp environment or near flammable material.
- The device requires an adequate flow of air in order to operate correctly. Leave a clearance of 15 cm around the appliance.
- **WARNING!** Do not close the ventilation openings in the device housing.
- The electrical socket must be easily accessible so that the power lead can be disconnected easily, in the case of an emergency.
- The installation and assembly of this device in non-stationary setup locations (e.g. on ships) must be carried out by specialist companies / electricians, provided they guarantee the prerequisites for the safe use of this device.
- For energy saving reasons please ensure that the door is closed when the appliance is turned on.

3.4.2 Feet

There are different feet (3 bigger feet and 1 small foot).

To level your device, adjust the small foot at the bottom of the device.

3.5 The handle installing

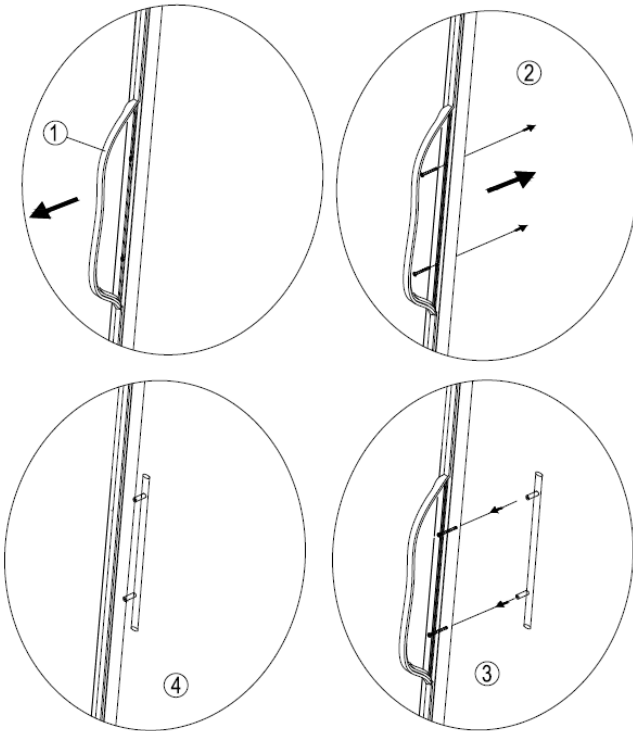

The device comes with one metal stainless steel handle. To install simply screw them to the door with the supplied screws.

To do this, slide the rubber seal on the back of the door to the side to lay open the predrilled holes. Use the included screws to install the handle on the door.

3.6 Electrical connection

In order to ensure the safe and trouble-free operation of the device, the following instructions must be observed for the electrical connection:

- Before connecting the device, compare the connection data (voltage and frequency) on the rating plate with those of

your electrical network. This data must agree in order that no damages occur in the device. If in doubt, ask your qualified electrician.

- The connection between the device and the electrical network may employ a 3 meter long (max.) extension cable with a cross-section of 1.5 mm². The use of multiple plugs or gangs is prohibited because of the danger of fire that is involved with this.
- Make sure that the power cable is undamaged and has not been installed under or over hot or sharp surfaces.
- This unit is not designed to be installed in an RV or used with an inverter.
- The electrical outlet must be protected by a 16A safety cut-out switch.
- The electrical safety of the device is only guaranteed if the device is connected to a properly installed protective conductor system. If in doubt, have the house installation checked over by a qualified electrician.

The manufacturer cannot be made responsible for damages that are caused by a missing or damaged protective conductor.

4 Design and Function

This chapter provides you with important safety notices on the design and function of the device.

4.1 Complete overview

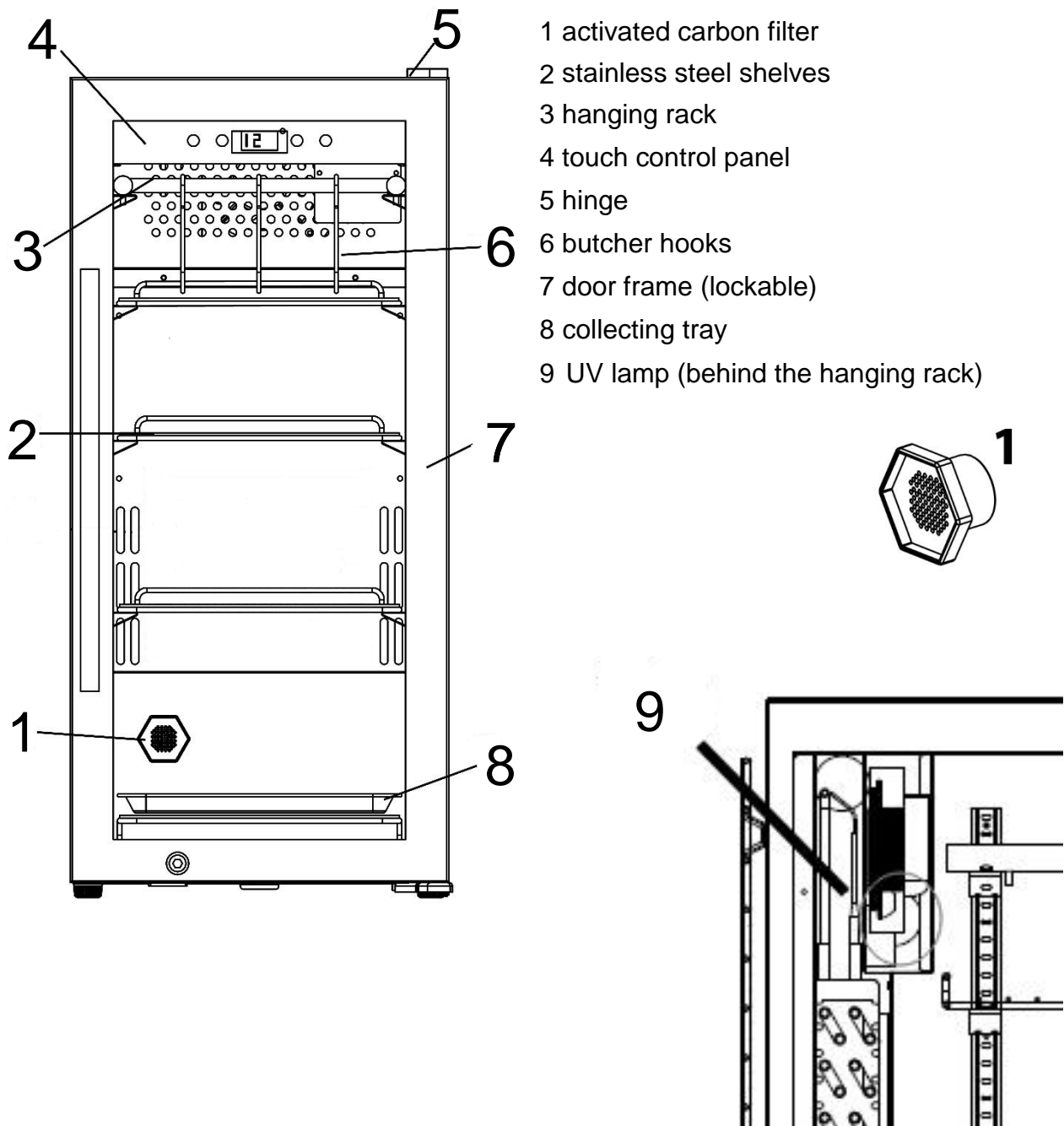

4.1.1 Removal of stainless steel shelves

To remove a stainless steel shelf, first remove the meat. Use gloves which are suitable for contact with food. Lift the stainless steel shelf upwards and then gently pull it out.

HINWEIS

PLEASE NOTE

- Carefully ensure that the stainless steel shelves and/or hanging rack for the butcher hooks is correctly locked into position before you place meat on it or suspend meat from it.

5 Operation and Handling

This chapter provides you with important notices with regard to operating the device.

5.1 Operating elements and displays

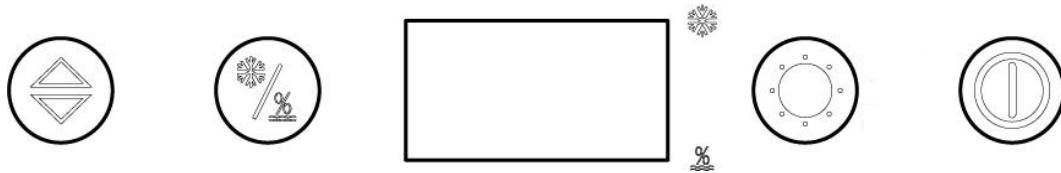

Setting the temperature (2- 14°C) and humidity (50% - 85%)



Change between the temperature and humidity settings

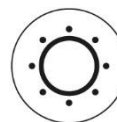

Press 1x: switch on LED light (switches off automatically after 4 hours)

Hold down for 5 seconds: UV light switches on

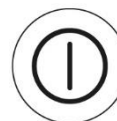

Switch the device on / off

5.2 Operation:

1. Please clean the device before use (see chapter “Cleaning and Maintenance”).

2. Press the  button to switch the device on.

3. Switch on the UV light for at least 2 hours to sterilize the interior.

To do this, press and hold the  button for 5 seconds.

4. H2O reservoir

Fill 300 ml of drinking water into each H2O reservoir before placing meat into the device. Remove the plastic packaging beforehand.

HINWEIS

Please note

► If the displayed humidity during the aging process does not match the desired setting, you have to rewet the H2O reservoir if the humidity is too low.

5. Setting the temperature or humidity:

With  you can switch between the setting and display of temperature or humidity.

Press the button  once, then the temperature flashes on the display and the temperature is adjusted from 2-14°C in 1°C steps.

Press the button  twice, then the humidity indicator flashes on the display and the humidity can be adjusted from 50-85% in 1% steps.

If you do not change the setting within 3 seconds, then the device will return to its previous setting. The device automatically returns to the temperature display.

HINWEIS

- ▶ Only hang / place the meat in the DryAger when the device has reached the desired temperature.
- ▶ Tip: For ideal maturity results we recommend the following setting: temperature 3°C / air humidity 75%.
- ▶  switch between the temperature display in °C and ° F by pressing the



and



buttons simultaneously for 3 seconds.

6. LED light and UV light setting

Press , to switch on the LED light, this switches off automatically after 4 hours.

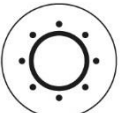
Press  for 5 seconds, the UV light will turn on.

HINWEIS

Please note

- ▶ The door has a safety switch. When you open the door of the device, the UV light switches off automatically. When you close the door, the UV light will turn on again.
- ▶ The UV light is used to clean the interior before, during and after the aging process.

5.2 Rating plate

The rating plate with the connection and performance data can be found on the back of the device.

6 Dry ageing

6.1 Safety information

HINWEIS**PLEASE NOTE**

- ▶ It is not important not to open the door much in order to avoid unnecessarily affecting the climate of the equipment/the humidity of the air.
- ▶ Have a butcher/expert whom you trust inform you about dry ageing.

⚠GEFAHR**Danger**

- ▶ Only use meat which is suitable for refinement.
- ▶ Wear gloves which are suitable for contact with food if you touch the meat and the metal shelves or meat hooks.
- ▶ A hazard of dry ageing is "wild fungi". Unlike "good edible fungi", this can spoil the meat and cause toxic and allergic reactions. For this reason, make sure that you maintain impeccable standards of hygiene when handling the meat and the equipment and have a butcher/expert whom you trust provide you with comprehensive information about dry ageing.
- ▶ If you notice a sourish smell, this may be an indication of "wild fungi".
- ▶ Once the ageing process has been completed, dark and dry patches of meat must be generously removed.
- ▶ Do not consume any food which has been superimposed on the meat, as you could suffer from food poisoning.

6.2 Exemption from liability:

The manufacturer will not assume any liability for damage to refrigerated products, not even in the event of a fault in the equipment during the guarantee period. The manufacturer will also not accept liability for injury to individuals resulting from improperly stored products which are subsequently consumed.

6.3 Information about dry ageing

The dry ageing of beef, pork and poultry is an expensive process and requires time and ideal conditions.

You will be able to store good quality meat on the metal storage shelves or to suspend it on the meat hooks inside the equipment.

Check the meat regularly for the presence of wild fungi.

If the degree of ageing which you desire has not been achieved, remove the meat, divide it into portions as you see fit and prepare it.

Various aromas, depending on the amount of ageing

Depending on the meat used, you will be able to obtain subtle, nutty aromas after around 21 days.

Depending on the meat, you will obtain aromas similar to those of fungi after around 28-35 days.

Depending on the meat used, you will be able to obtain powerful aromas similar to that of blue cheese after around 45 days and longer.

The longer you allow the meat to age, the stronger the aroma will be.

7 Cleaning and Maintenance

This chapter provides you with important notices with regard to cleaning and maintaining the device. Please observe the notices to prevent damages due to cleaning the device incorrectly and to ensure trouble-free operation.

7.1 Safety information

▲VORSICHT Attention

Please observe the following safety notices, before you commence with cleaning the device:

- ▶ Prior to commissioning, clean the appliance thoroughly.
- ▶ Clean the device thoroughly after each ageing process.
- ▶ Before cleaning, switch the dry ageing cooler off, remove the plug from the wall socket and remove all the meat.
- ▶ Do not use any aggressive or abrasive cleaning agents or solvents.
- ▶ You must use a food-compatible cleaner that is not too aggressive for the surfaces of the device.
- ▶ Do not scrape off stubborn dirt with hard items.
- ▶ If you do not use the equipment for a fairly long period of time, you should remove all the metal shelves, the metal suspension system and the meat hooks and you should clean the equipment thoroughly.
- ▶ If the maturing process has failed and the meat is spoiled or wild fungi has developed, then please contact our customer service to coordinate the further steps.

◆ Interior and exterior walls

Clean the interior and exterior walls with lukewarm water and a little washing-up liquid. Never use cleaning or chemical solvents containing sand or acid.

Then wipe the device thoroughly with a soft cloth.

Switch on the UV light for 24 hours after each ripening process.

◆ Housing

Use a glass cleaner to clean the glass surfaces and a commercially available stainless steel cleaner for stainless steel surfaces

Then wipe the device thoroughly with a soft cloth.

◆ Container for condensed water (K)

Check container for the condensed water regularly. It is located on the rear right of the device. If necessary, remove the condensed water with a sponge.

◆ Manual defrosting

Defrost the device after each ageing process.

Turn off the power but do not unplug the power plug. Let the device then defrost manually. Pay attention to the container for condensed water(K) and remove the condensed water during the defrosting.



◆ **If the device is iced up, proceed as follows:**

Remove the meat from the device. Cover it with cling film or, if possible, place it in a foil bag and refrigerate it in a suitable refrigerator. Switch off the device.

Fill the pot with hot tap water but water which is no longer boiling and place the pot on a cloth on the lower metal shelf.

▲ WARNUNG **Warning: Risk of scalding due to the hot pot.**

▶ Exercise caution when using the hot pot.

The steam will melt the ice within about an hour.. The melt water will be collected in the interior of the device and possibly in the container for condensed water (K). Remove the pot and the cloth from the device. Wipe the water out of the interior and empty the drip tray (K). Wipe the device dry with a soft cloth. Leave the device open for 1 hour so the device can ventilate.

◆ **Stainless steel shelves, hanging rack, collecting tray and butcher hooks**

Remove the Stainless steel shelves, hanging rack, collecting tray and butcher hooks from the device and clean them with warm water and detergent for hygiene reasons. Dry the components properly.

◆ **Activated carbon filter**

- Replace the activated carbon filter once a year. To do this, remove the meat (if necessary), unscrew and replace the filter.
- You can order replacement activated carbon filters from us.

7.2 Changing the UV lamp

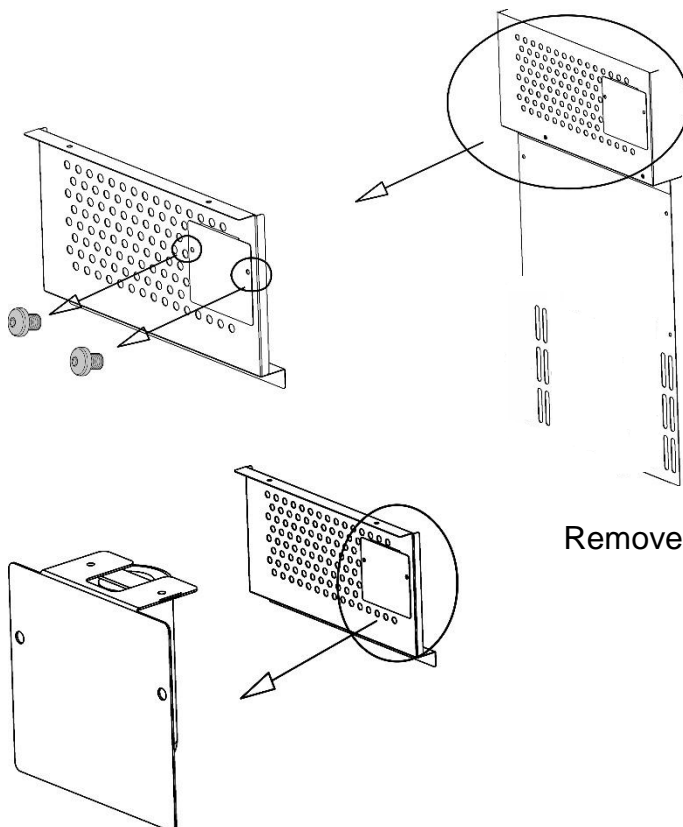

Carefully loosen the screws.

Remove the cover. The UV lamp is attached to this.

Pull the cover of the UV lamp downwards and replace the lamp.

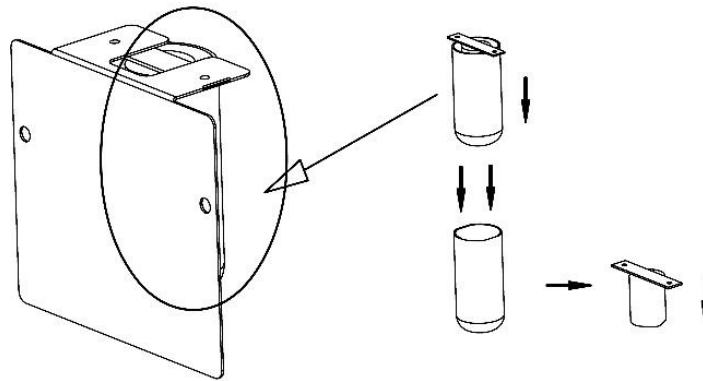

Installation backwards accordingly.

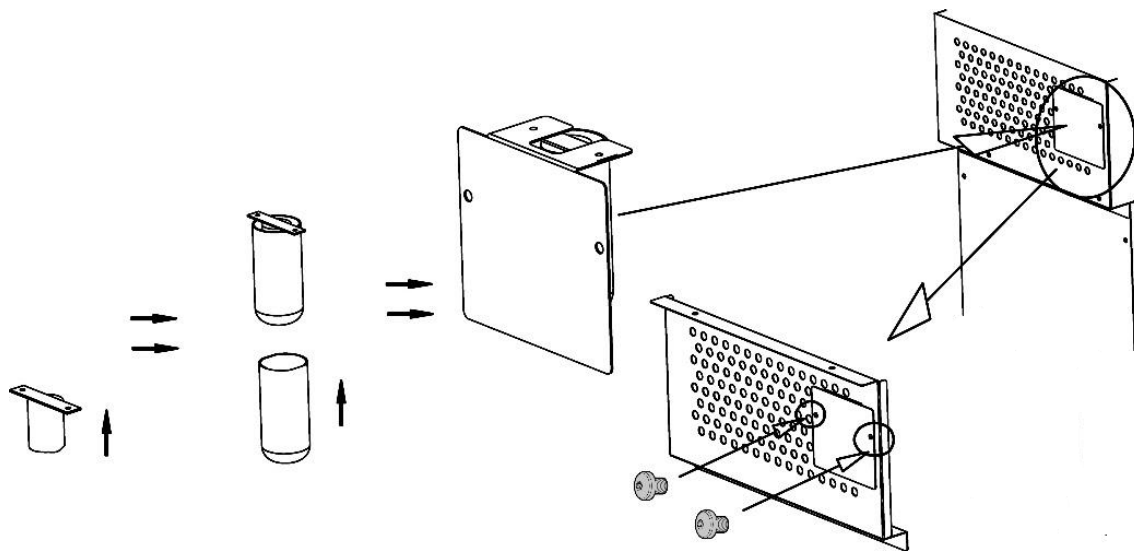

7.3 Moving the appliance

Turn off the appliance first. Remove all content. Shurely tape down all lose items inside your appliance. Tape doors shut. Be sure the device stays in the upright position during transportation.

8 Troubleshooting

This chapter provides you with important notices with regard to operating the device. Observe the following notices to avoid dangers and damages:

8.1 Safety notices

▲VORSICHT Attention

- ▶ Only qualified electricians, who have been trained by the manufacturer, may carry out any repairs on electrical equipment.
- ▶ Improperly performed repairs can cause considerable dangers for the user and damages to the device.

8.2 Fault indications and rectification of faults

The following table assists in localizing and rectifying minor faults.

Fault	Possible Cause
Device is not cold enough.	Check the temperature control setting. External environment may require a higher setting. The door is open too often. The door is not closed completely. The door seal does not seal properly. The device does not have the correct clearance. Defrost the device.
The light does not work.	Contact customer service.
Vibrations & too much noise & door does not close properly	Check to assure that the device is level. Check the fan. Components are loose. Device touches the wall. The door is reversed and not properly installed. The seal is weak. The shelves are out of position.
The display does not work. Buttons are not functional.	Pull out the mains plug, wait 2 minutes, plug in the mains plug again. If this does not solve the problem, then please contact customer service.
Compressor will not start	Room temperature is lower than desired temperature.
Dew on the surface of cabinet :	The surface of the device especially the glass door appear some frost if item in a damp room. This is due to the moisture in the air coming into contact with the cabinet. Please wipe it away with dry cloth.
Liquid sound	1 The sound of compressor when starts or stops working 2 The flowing sound of refrigerant in the refrigeration system 3 The evaporating sound of refrigerant in the evaporator
Condensation formed inside the cabinet	Under the environment with high level of humidity or the door of device has been left open for a long period or opened frequently, wipe off the door and walls and leave the door closed as long as possible.

Error code	Problem	Solution
H1	Problem with contact of door.	Contact customer service
H2	Problem with temperature sensor.	Contact customer service
H3	Problem with cooling	Contact customer service
H4	Problem with humidity	Contact customer service
H5	Problem with humidity sensor	Contact customer service
H6	Problem with defrosting	Defrost the device
E9	Problem with signal cable	Contact customer service

HINWEIS

PLEASE NOTE

- ▶ If you are unable to solve the problem with the steps shown above, please contact Customer Service.
- ▶ Clean the metal shelves, collecting tray and the meat hooks with disinfectant and remove the remains of any meat from the equipment before you send the equipment in.



9 Disposal of the Old Device

Old electric and electronic devices frequently still contain valuable materials. However, they also contain damaging substances, which were necessary for their functionality and safety. If these were put in the non-recyclable waste or were handled incorrectly, they could be detrimental to human health and the environment. Therefore, do not put your old device into the non-recyclable waste under any circumstances.

HINWEIS

PLEASE NOTE

- ▶ Utilise the collection point, established in your town, to return and recycle old electric and electronic devices. If necessary, contact your town hall, local refuse collection service or your dealer for information.
- ▶ Ensure that your old device is stored safely away from children until it is taken away: Before you throw away your old refrigerator take off the doors and leave the shelves in place, so that children may not easily climb inside.
- ▶ Blowing gas inside the unit is flammable. The disposal of this flammable material should be in accordance with national regulations.