

TRANSLATION OF ORIGINAL INSTALLATION AND MAINTENANCE MANUAL SMART OVENS

MKF 464 S- MKF 416 S - MKF 511 S
MKF 664 S – MKF 664 SP – MKF 621 S – MKF 616 S – MKF 711 S
MKF 1064 S – MKF 1021 S – MKF 1016 S MKF 1111 S
MKF 1664 S – MKF 2011 S

CONTENTS

1. SERVIZIO TECNICO (TECHNICAL SERVICE)	2
2. GENERAL INFORMATION	2
3. INSTRUCTIONS FOR THE INSTALLER	2
3.1 Storage	2
3.2 Transportation of the appliance	2
3.3 Unpacking the appliance	3
3.4 Removal of the protective film	3
3.5 Protective film/package disposal	3
3.6.1 Table top oven placement	3
3.6.2 Stacking ovens on other appliances	4
3.6.3 Placement of floor-standing ovens with trolley	4
3.7 Electrical connection	4
3.8 Power supply cable connection (replacement)	5
3.9 Type of connection to the mains	5
3.10 Connection to the water mains	7
3.11 Water drain	7
3.11.1 Water drain for floor ovens	8
3.11.2 Water drain for tabletop ovens	8
3.12 Steam drain	8
4. MAINTENANCE INSTRUCTIONS	9
4.1 Access to the components for inspection	9
4.2 Safety thermal devices	9
4.3 Replacing the cooking chamber gasket	10
4.4 Handle closure adjustment	10
4.5 Checking the cooking chamber gasket "seal"	10
4.6 Residual risks	11
5. TROUBLESHOOTING	11
6. TECHNICAL SUPPORT	11
7. DISPOSAL OF THE APPLIANCE	12
8. CONVENTIONAL WARRANTY	12
9. AVAILABILITY AND SUPPLY OF SPARE PARTS	13
10. APPLICABLE LAW AND COMPETENT COURT	13

1. SERVIZIO TECNICO (TECHNICAL SERVICE)

For periodic maintenance checks and repairs, contact your nearest Support Centre and only use original spare parts. Failure to comply with this provision shall forfeit the warranty right.

2. GENERAL INFORMATION

It is essential for this instruction manual to be stored together with the appliance for future referencing; in the event of misplacing it, a copy must be obtained directly from the manufacturer.

This information has been prepared for your safety and that of others; therefore we kindly ask you to read it carefully before installing and using the appliance.

Upon reception of the goods, if the **packaging** is not intact or is damaged, report the following: **"GOODS SUBJECT TO INSPECTION"**, with the specification of the damage and countersigned by the driver; file a written complaint with the vendor within 4 calendar days (not business days) from the date of delivery, after which no complaints shall be accepted.

The appliance is intended for professional use in industrial and professional kitchens and must only be used by skilled personnel who have been trained on its proper use. For safety reasons the appliance must be supervised during operation.

The appliance is not intended to be used by children and/or persons with impaired physical, sensory or mental abilities, or who lack experience or knowledge, unless they are supervised by a person responsible for their safety, or who has been instructed on using the appliance.

It is hazardous to modify or attempt to modify the features of this appliance.

The appliance must never be cleaned with direct water or steam jets, since any ingress of water might affect its safety.

Before maintenance or cleaning disconnect the appliance from the power supply mains and let it cool.

In the event of failure or poor operation, switch off the appliance, close the water supply cock, disconnect the power supply and contact an authorised Support Centre.

Any modification to the electrical system that might be required to install the appliance must be carried out by competent personnel only.

All installation and commissioning operations must exclusively be performed by technically skilled installers, according to the manufacturer's instructions and in compliance with national standards in force.

Note: The inappropriate or incorrect use and failure to comply with installation rules shall invalidate any Manufacturer liability. To this regard, the instructions laid out in the **"POSITIONING"** paragraph must be strictly complied with.

3. INSTRUCTIONS FOR THE INSTALLER

The following instructions are intended for skilled installers, to perform installation, electrical and water connection operations in the most correct manner and according to the safety regulations in force in the country of installation of the appliance.

The Manufacturing Company shall not be liable for damage or harm to persons, pets or property arising from installation errors. Nor are they responsible for any appliance breakage caused by faulty installation.

3.1 Storage

If the appliance is stored in a warehouse, the ambient temperature must never drop below 0°C. Before switching on the appliance it must be brought to a temperature of at least +10°C.

3.2 Transportation of the appliance

During transportation the appliance must be left in its packaging in order to protect it from any external damage.

The weight of the appliance must also be taken into account in order to prevent overturning.

3.3 Unpacking the appliance

Remove the packaging before installation. It consists of a wooden pallet supporting the appliance and a cardboard casing protecting it. Ensure the appliance has not undergone any damage during transport; otherwise immediately alert your dealer and/or carrier.

3.4 Removal of the protective film

Before using the appliance accurately remove the special film protecting the stainless steel components, avoiding glue residues on the surfaces; if required, immediately remove them using an appropriate non flammable solvent. Do not use any tools that might scratch the surfaces or any acid-based or abrasive detergents.

3.5 Protective film/package disposal

TECNOEKA has been committed for years to increasing the environmental compatibility of its equipment, with continuous efforts to reduce energy consumption and waste. TECNOEKA intends to protect the environment and recommends to dispose of all different types of material, in the appropriate separate collection containers.

The protective film and packaging must be disposed of in strict compliance with the regulations in force in the country of installation of the appliance. **The various materials** (wood-paper-carton-nylon-metal tacks) that may comprise the packaging are potentially dangerous and must be kept out of reach of children and animals; **they must be duly separated and delivered to the respective collection centres** (recycling centres). In any case please adhere to the local environmental protection regulations.

3.6 Placement

Check the place of installation making sure that the transit areas (any doors and corridors) are sufficiently wide and the floor supports the appliance's weight (the appliance's weight and dimensions with/without pallets are provided in the attached "Technical Data Sheet"). The appliance must be transported with mechanical means (e.g. pallet jack). The installation rooms must be well-ventilated with permanent aeration vents; must be equipped with the proper electrical and hydro systems, built in accordance with the standards related to facilities and workplace safety in the country of installation.

The maximum working height, referring to the highest surface level, must be 1.6 metres from the floor.

After installing the appliance, if required, apply the suitable adhesive symbol  (supplied) at a height of 1.6 metres. To favour air circulation around the appliance, leave a space of about 10 cm between the appliance sides and the surrounding walls (or other appliance), and between the back and the back wall (see the attached "Technical Data Sheet"). The appliance must be positioned so that the rear wall is easily accessible to set up various electrical connections and to carry out any possible maintenance. Do not install the appliance near any equipment that may reach high temperature values (e.g. deep fryers).

Should the appliance be installed near walls, shelves, counters and the like, these must be non-flammable or heat-resistant; otherwise, they must be protected by adequate fire retardant coating. Accordingly, it is indispensable to act in compliance with the fire prevention regulations in force.

Cooking produces hot smoke/vapour and odours which are extracted through the suitable vent device

located at the top of the appliance and marked with the symbol . It is recommended to place the appliance under an extraction hood or to use the suitable **TECNOEKA. condensation hoods** in order to convey the smoke/vapour to the outside.

Warnings

Make sure there are no objects and/or materials obstructing the oven's exhaust device.

The hot smoke/vapour produced during cooking must run freely out of the exhaust device in order not to compromise the regular operation of the oven.

Inflammable materials must not be left near the oven's exhaust device.

3.6.1 Table top oven placement

The appliance must be placed in a perfectly horizontal position on a table or similar support; **never on the floor**. To facilitate oven levelling, the feet are adjustable in height.

For safety reasons it is recommended to use the specific table produced by **TECNOEKA**; otherwise the dimensions and weight of the appliance must be taken into account.

The appliance is unsuitable for recessed installation and cannot work without the 4 supporting feet.

Warning

If the appliance is positioned on a wheeled table/support, ensure that the intended movement does not damage electrical wires, water pipes, drain pipes or anything else.

3.6.2 Stacking ovens on other appliances

When stacking two appliances **only** the specific "STACKING KIT" supplied by TECNOEKA can be used. **THE MANUFACTURING COMPANY DISCLAIMS ANY LIABILITY FOR DIRECT OR INDIRECT DAMAGE CAUSED TO THE HOOD DUE TO FAILURE TO COMPLY WITH THIS DIRECTIVE.**

For correct "STACKING KIT" installation operations, follow the instructions provided inside the package.

Warnings

An oven must never be stacked directly on another oven or another heat source.

If you have to use the "STACKING KIT" (to stack the appliances), be very careful not to damage the "ON/OFF" button under the oven base (upper).

3.6.3 Placement of floor-standing ovens with trolley

The appliance must be positioned on a flat and level floor that can sustain the weight of a "full load" without collapsing or deforming. After placement, make sure that the appliance is aligned horizontally. This check may be carried out by placing a "spirit" or digital level on the 4 top sides of its casing.

Ensure that the tray trolley is able to go in and out of the cooking chamber easily, without rubbing against the lower surface, even with "full load". Otherwise the appliance feet must be adjusted to lower it so that the tray trolley can move properly. In any case, when the adjustment is complete, **ensure that the wheels of the tray trolley inserted in the cooking chamber are raised off the floor (by not more than 5 mm), and that the trolley is supported by the guides at the bottom of the appliance.**

The tray trolley must be moved using the supplied grip. The grip must be inserted into place at the front of the trolley up to the "stopping point".

The tray trolley must be inserted inside the cooking chamber, freely sliding on the guides in the lower portion of the appliance.

Warning

The appliance may malfunction unless the tray trolley is correctly positioned.

3.7 Electrical connection

The appliance's connection to the electric power network and the connection systems must comply with the applicable regulations in the country of installation. Before setting up the electrical connection ensure that:

the voltage and frequency of the power supply system match the specifications of the "technical data" plate affixed to the side of the appliance;

the power supply system is able to withstand the appliance's load (see "technical data" plate);

the power supply system is fitted with an effective earthing connection according to the regulations in force;

in the permanent connection to the electric power network, a protective pole switch must be placed between the appliance and the mains (e.g. circuit breaker) with minimum opening between the contacts of overvoltage category III (4000V) and a differential switch, sized for the load and complying with applicable regulations.

the protective pole switch used for the connection is easily accessible when the appliance is installed;

the yellow/green earthing cable is not interrupted by the switch;

when the appliance is running, the power supply voltage does not deviate from the rated voltage value by $\pm 10\%$.

Ensure that the power supply cable does not come into contact with the appliance's hot parts.

If the power supply cable is damaged, it must be replaced by the manufacturer or their technical support service, or in any case by a person with similar qualifications, to prevent any risk.

The appliance must be connected to an equipotential system the effectiveness of which must be suitably assessed according to applicable regulations. This connection must be set up between appliances through the suitable terminal which is marked with the symbol . The equipotential conductor must have a minimum section of 2.5mm².

The equipotential terminal is on the back of the appliance (see the attached "Technical Data Sheet").

3.8 Power supply cable connection (replacement)

The appliance is fitted with a power supply cable (except for models MKF 1664 BM and MKF 2011 BM) connected to the internal terminal board; if it needs to be replaced with a longer one or because it is damaged, it can only be done with another cable having the same electrical characteristics (insulation type/number of conductors/size of conductors in mm²).

Remove the back and/or the left side of the appliance to access the power supply terminal board. Loosen the cable retainer located on the rear (at the bottom) of the appliance (see the attached "Technical Data Sheet"). Disconnect the power supply cable from the terminal board and remove it from the relative cable gland. Insert the new power supply cable in the cable gland up to the terminal board. Prepare the conductors for the connection with the terminal board so that the earth conductor is the last to be extracted from its terminal should the cable be accidentally pulled.

The cable connection must be **type "Y"** and the insulation of the cable sheath must match type **H07RN-F**. **The correct section of the cable is shown on the diagram of the power supply terminal board, according to the type of connection between appliance and mains** (The cable must match the features in the attached "Technical Data Sheet").

When connected, tighten the cable retainer on the back of the appliance and reassemble the left side and/or the back.

3.9 Type of connection to the mains

400V 3PH + N ~

Connect the 3 **phase** conductors (**L1, L2, L3**) of the cable respectively to the terminals of the terminal board marked with **"1" (brown conductor), "2" (black conductor) and "3" (grey conductor)** and the **neutral (N)** conductor to the terminals marked with **"4" or "5" (blue conductor)**; the **earth** conductor (**yellow/green**) must be connected to the terminal marked with the symbol  (see diagram available by the terminal board).

230V 3PH ~

Connect the 3 **phase** conductors (**L1, L2, L3**) of the cable respectively to the terminals of the terminal board marked with **"1" and "2" (brown conductor), with "3" and "4" (black conductor) and with "5" (grey conductor)**; the **earth** conductor (**yellow/green**) must be connected to the terminal marked with the symbol  (see diagram available by the terminal board).

230V ~

Connect the conductor of **phase (L)** of the cable to the terminals of the terminal board marked with **"1", "2" and "3" (brown conductor)** and the **neutral (N)** conductor to the terminals marked with **"4" and "5" (blue conductor)**; the **earth** conductor (**yellow/green**) must be connected to the terminal marked with the symbol  (see diagram available by the terminal board).

Mod. MKF 416 S – MKF 464 S – MKF 511 S

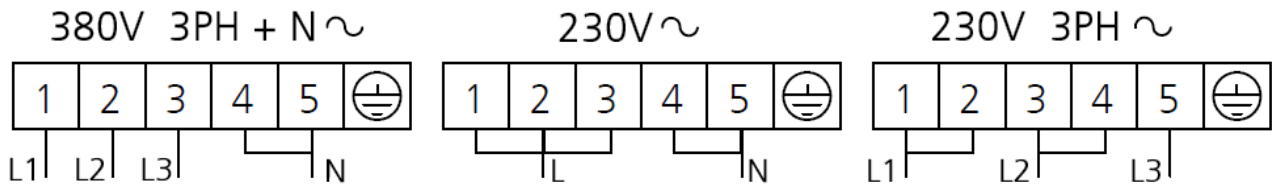

Mod. MKF 616 S - MKF 664 S – MKF 664 SP – MKF 711 S

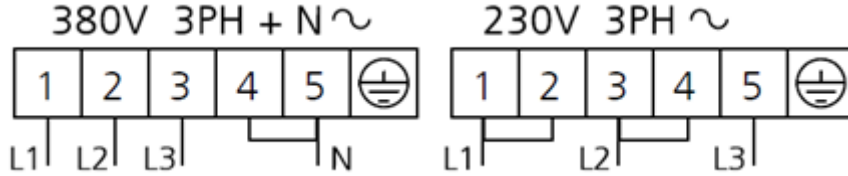

Mod. MKF 621 S

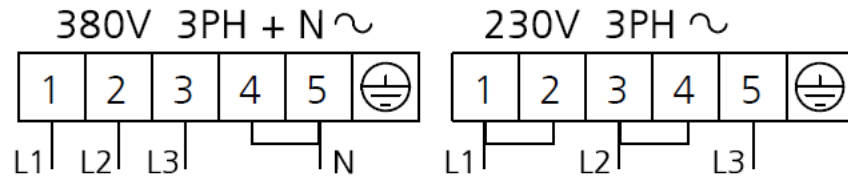

Mod. MKF1016 S - MKF 1064 S – MKF 1111 S

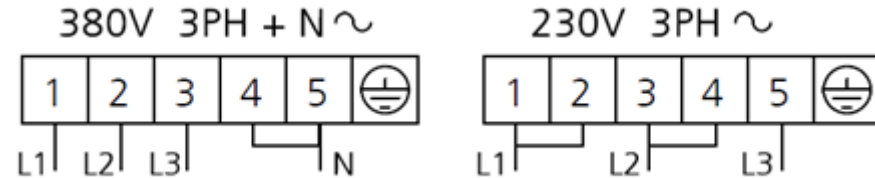

Mod. MKF 1021 S

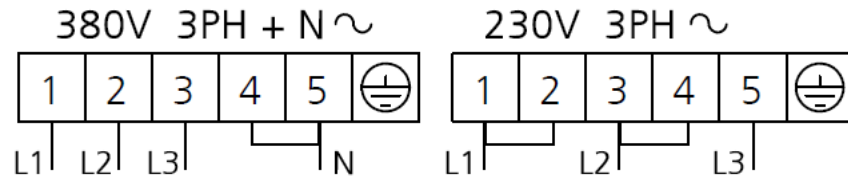

Mod. MKF 1664 S – MKF 2011 S

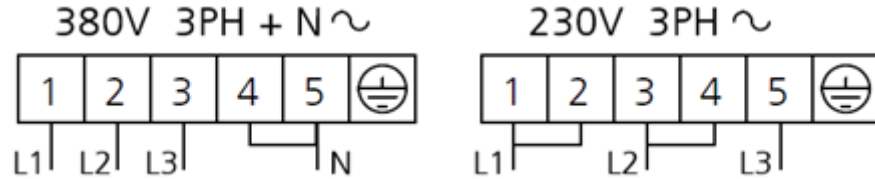

3.10 Connection to the water mains

The appliance must be supplied with drinking water at a maximum temperature of 30°C.
The water pressure must be between 100 and 200 kPa (1.0 -2.0 bar).
If the mains pressure exceeds 2.0 bar, install a pressure reducer upstream of the appliance.
If the value is lower than 1.0 bar use a pump to raise the pressure.

3.10.1 Water inlet for humidification / steam

Exept for mod. MKF 664 SP.

The appliance is equipped with a standardised flexible hose (1.5 metres) with threaded ¾" female fittings and relative gaskets (Fig. 1). Old joints must not be re-used.

The appliance must be supplied with **softened drinking water** with hardness between 0.5°f and 3°f. It is **obligatory to use a softener** to reduce the formation of limescale inside the cooking chamber. **THE MANUFACTURING COMPANY DISCLAIMS ANY LIABILITY FOR DIRECT OR INDIRECT DAMAGE CAUSED TO THE HOOD DUE TO FAILURE TO COMPLY WITH THIS DIRECTIVE.**

The connection to the water mains must be set up through the ¾" threaded solenoid valve located on the back (at the bottom) of the appliance (see the attached "Technical Data Sheet"), using the supplied flexible hose, with a mechanical filter and stopcock installed in between (before connecting the filter, drain off a certain amount of water to flush any dirt out of the hose).

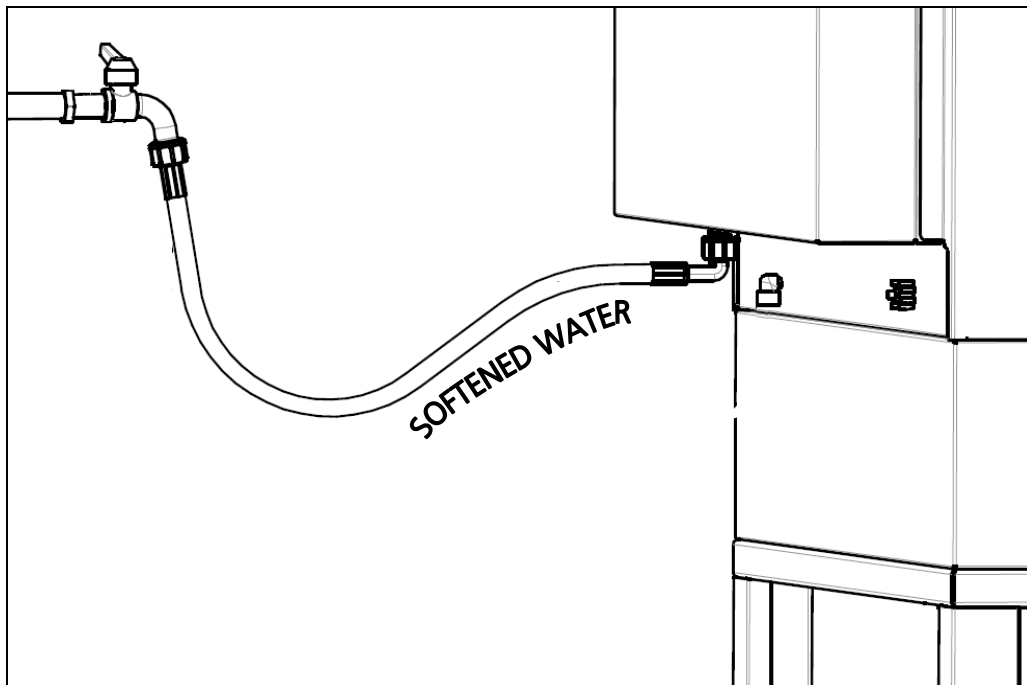

Fig.1

Warning

Any damage caused by limescale or other chemicals contained in the water are not covered by warranty.

3.11 Water drain

Exept for mod. MKF 664 SP.

A drain pipe comes out of the rear of the appliance (see the attached "Technical Data Sheet") to drain the cooking chamber. This pipe must be connected to piping with 30 mm internal diameter (DN 30) resistant to steam temperatures (90°C-100°C): avoid metal ones.

The piping must be rigid and must not have bottlenecks along the discharge path (it is advisable to use commercial pipes of special plastic material, with an internal "sealing" O-RING, and to limit the use of "elbow" bends).

The piping must also maintain a steady slope (min. 4-5%) along its entire length.

The considered length is that of the drain pipe of the appliance to the discharge point and must not exceed the measurement of 1.5 meters.

It is mandatory to connect the appliance's drain to the grey water network **through an adequate trap**, in order to stop steam/odours from coming out of the drain. The connection to the drain water must be set up separately for each appliance; with multiple appliances connected to the same drain pipe, ensure that the pipe is suitably sized to assure regular drainage with no hindrances.

3.11.1 Water drain for floor ovens

The drain pipe is conveyed to an open (grilled) floor drain (Fig.3) and should not go into direct contact with the discharge point: the "air gap" (distance between the drain pipe coming from the appliance and the open drain) must be at least 25 mm.

Wall-mounted discharge is also allowed as long as the drain pipe maintains the steady slope of 4-5%.

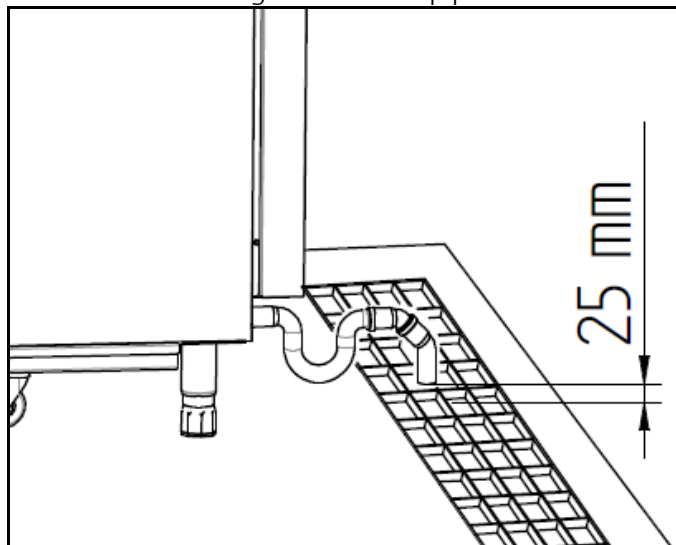

Fig.3

3.11.2 Water drain for tabletop ovens

The exhaust pipe can be conveyed to an open (grilled) floor drain (Fig.4); otherwise, between the drain pipe of the appliance and the drain point with a "collection cup" (Fig. 5), there must be a height difference of at least 30 cm in order to facilitate regular flow of water. In any case, the "air gap" (distance between the drain pipe from the appliance and the open drain or the "collection vessel" of the drain duct pipe) must be at least 25 mm.

Wall-mounted discharge is also allowed as long as the drain pipe maintains the steady slope of 4-5%.

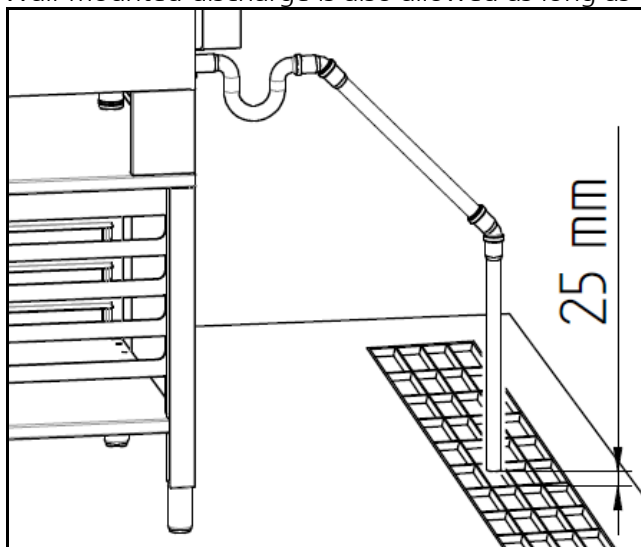

Fig. 4

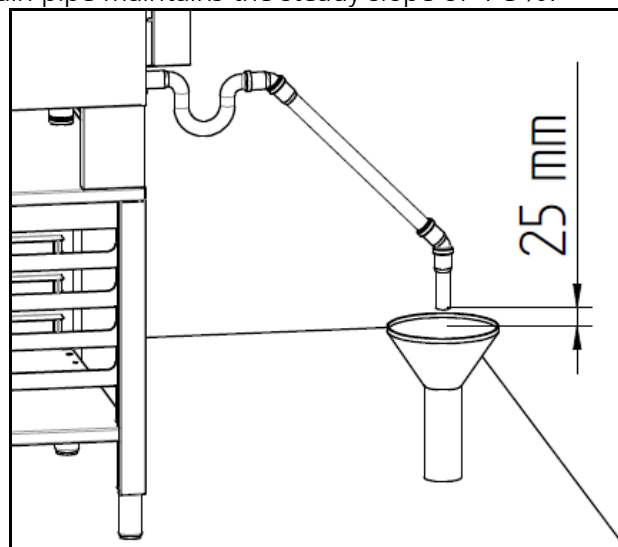

Fig. 5

3.12 Steam drain

The appliance is equipped with a special metal pipe (DN30) for the discharge of steam from the cooking chamber.

No other type of pipe can be connected to this pipe, which protrudes from the back of the casing.

Failure to comply with this specific prohibition shall relieve the Manufacturer from any liability concerning the potential malfunction of the appliance and poor cooking quality.

Increasing the length of the original drain hose may result in the formation of abnormal "condensation" in the cooking chamber.

To prevent steam from escaping from the exhaust pipe, place the appliance under the extractor hood, or connect it to the "TECNOEKA" extractor hood/condensing hood, specific for the appliance model used.

4. MAINTENANCE INSTRUCTIONS

A periodic check (at least once a year) of the appliance contributes to extending its service life and assures proper operation.

Any maintenance operation on the appliance must only be done by highly qualified personnel trained in the operations being performed and authorised by **TECNOEKA**. Operations must be carried out in accordance with the safety regulations in force in the country where the appliance is installed, pursuant to the regulations relative to plants and to workplace safety.

Before carrying out any maintenance on the appliance it must be disconnected from the mains and allowed to cool down.

The Manufacturer is not responsible for any appliance faults caused by defective maintenance.

4.1 Access to the components for inspection

Removing the left side:

- Magnetic door sensor (door opening to the right)
- Control thermostat bulb (door opening to the left)
- Contactors
- Anti-interference filter (if any)
- Condensation hood control terminal block (if any)

Removing the back;

- Tangential motor (on the back)
- Circular resistors
- Radial motors
- Contactors
- Power supply terminal board
- Safety thermostat
- Capacitors
- Humidification solenoid valve
- Magnetic door sensor control transmission relay
- Cam programmer (Motor reversing gear)
- Humidification piping/fittings unit

Removing the right side:

- Magnetic door sensor (door opening to the left)
- Control thermostat bulb (door opening to the right)
- 12-way electrical wiring connector for controls (on door)

Removing the control protection box (on door):

- Timer ("End of cooking")
- Regulation thermostat
- Automatic humidifier
- Warning lights

Opening the glass inside the door

- Cooking chamber lighting lamp (LED)

4.2 Safety thermal devices

The appliance is equipped with a (manually reset) safety thermostat, to protect against excessive and hazardous overheating which might accidentally occur inside it. If the safety thermostat is activated, the power supply to the appliance is cut off.

The safety thermostat is located at the back (bottom) of the appliance (see the attached "Technical Data Sheet"); to reset it after it has tripped, unscrew the protective cap using an appropriate tool and press the "reset" button all the way. Replace the protective cap so that it cannot be unscrewed without the use of a tool.

Important

Safety thermostat should only be reactivated after eliminating the anomaly that caused them to trip. This can only be done by a Service technician.

4.3 Replacing the cooking chamber gasket

The cooking chamber gasket has a rigid profile with retaining fins. This profile must be inserted in the suitable perimeter seat on the "front" of the chamber.

To replace the gasket, simply remove the used one from its seat (pull tightly near the 4 corners) and, after cleaning any impurities from the seat, insert the new gasket (to facilitate the assembly, it is recommended to wet the profile of the gasket with soapy water).

4.4 Handle closure adjustment

Should the door handle not close properly, check and if required adjust the position of the "nose" (cross-shaped) as follows:

with the oven door open, loosen the 2 screws that secure the "nose" support;

move the support vertically (upwards or downwards) and fasten it so that when the door is pushed with the handle completely open (horizontal position), the "nose" can fit into the handle without rubbing.

after adjustment, with the door closed, the handle must be in a perfectly vertical position (the end portion of the "nose" must be perfectly horizontal).

Warning

The door handle must only be adjusted after positioning the oven in a perfectly horizontal (levelled) way.

4.5 Checking the cooking chamber gasket "seal"

If the gasket on the "front" of the cooking chamber does not ensure proper "sealing" on the inside glass of the door, adjust the position of the 2 hinges (upper and lower) of the door and/or the (cross-shaped) handle "nose" projection by doing the following:

Loss of "tightness" on the hinges side

With the door closed, loosen the 6 screws securing the lower hinge (3 screws) and upper hinge (3 screws) of the door; push the door slightly to the side of the hinges so that the inner glass leans on the "front" gasket; hold the door slightly pressed in the direction of the hinges and secure them by tightening the 6 previously loosened screws. At the end of the operation, visually check, on the hinged side, that the door is perfectly parallel to the "front" of the cooking chamber.

Loss of "tightness" on the "nose" side

With the door open, loosen the locknut that secures the "nose" to its support; screw (clockwise) the "nose" by a full turn so that the end (cross-shaped) piece is perfectly horizontal again; screw on the previously loosened locknut. At the end of the operation, close the door, and check for slight resistance when turning the handle: this means that the "front" gasket is pressing ("sealing") slightly on the inside glass of the door.

If you do not feel any resistance, repeat the entire operation by screwing on the "nose" another full turn.

Warning

After performing all the operations necessary to restore the proper "sealing" of the gasket on the inside glass of the door, check its tightness by running the oven: for at least 30 minutes, with a 100% humidification cycle and with a cooking chamber temperature of 110°C. During oven operation no steam must escape from the door.

4.6 Residual risks

Do not use the door handle to move the appliance: this may deform the door frame.

The appliance is fitted with electrical parts: it must never be washed with a water or steam spray.

The appliance is electrically connected: disconnect the power supply before performing any type of maintenance.

To avoid incorrect connections of the appliance, the relevant electrical/water connections are marked on the appliance by suitable identification plates.

Only for wheeled models (MKF 1664 BM – MKF 2011 BM)

After installing the oven, ensure the tray trolley can be handled with ease, on smooth floors and with no hindrance to insertion and extraction operations: the trolley is mounted on wheels, any collision may cause the hot cooking food and/or liquids to spill and may even cause it to tip over.

5. TROUBLESHOOTING

Type of fault	Cause of the fault	Corrective action
Control panel warning lights totally off (The oven does not work)	- Non-compliant connection to the power mains	- Check the connection to the mains
	- No mains voltage	- Restore the power supply voltage
	- Safety thermal device triggered	- Restore the safety thermal device
Cooking cycle set: the oven does not work	- Door open or ajar	- Close the door properly
	- Door sensor damaged	- Contact a skilled technician
Automatic humidifier active: no humidity/steam production in the cooking chamber	- Non-compliant water mains connection	- Check the connection to the water mains
	- Closed stopcock	- Check the cock
	- Obstructed water inlet filter	- Clean the filter
	- Damaged water inlet solenoid valve	- Contact a skilled technician
Closed door: steam escapes through the gasket	- Non-compliant gasket assembly	- Check gasket assembly
	- Damaged gasket	- Contact a skilled technician
	- Handle "nose" adjusted incorrectly	- Contact a skilled technician
The oven does not cook evenly	- One of the motors is down or operates at low speed	- Contact a skilled technician
	- The motors do not reverse direction	- Contact a skilled technician
	- Resistor not powered or damaged	- Contact a skilled technician
Lamp (LED) in the cooking chamber does not work	- Lamp (LED) damaged	- Replace the lamp (LED)
The thermal safety device is activated continuously	- Damaged device	- Contact a skilled technician
	- Control thermostat damaged	- Contact a skilled technician

6. TECHNICAL SUPPORT

Before leaving the factory this appliance has been calibrated and tested by experienced and skilled personnel in order to obtain the best operating results. Any repair or calibration must be carried out with the utmost care and attention, using only original parts.

That is why it is always necessary to contact the Dealer who sold the appliance or our nearest Technical Support Centre, specifying the kind of failure and what model you have. For servicing needs the user may contact Tecnoeka on the numbers shown on the cover, or refer to the website www.tecnoeka.com.

7. DISPOSAL OF THE APPLIANCE

In accordance with Directive 2012/19/EU on the disposal of waste electrical and electronic equipment, the crossed-out wheeled bin symbol on the equipment indicates that the product was placed on the market after 13 August 2015, and that at the end of its services life it must be disposed of separately from other waste.

At the end of the appliance's service life, the user must, therefore, deliver it to the appropriate centres (recycling centres) for the separate collection of electrical and electronic waste.

All TECNOEKA appliances are made of recyclable metal materials (stainless steel, galvanised sheet metal, iron, copper, aluminium, etc.) which make up more than 90% of the total weight of the appliance. Before disposing of the appliance, it is recommended to make it unusable by removing the power supply cable and removing the mechanism for closing compartments and/or openings, if any.

The separate waste collection and subsequent treatment, recovery and disposal, are conducive to the production of equipment with recycled materials and reduce the negative effects on the environment and health possibly caused by incorrect waste handling. Illegal disposal of the product by the user entails the application of administrative penalties.

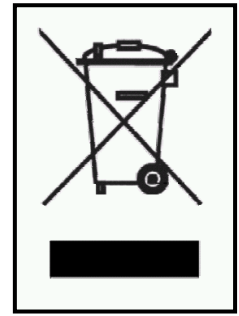

8. CONVENTIONAL WARRANTY

The Tecnoeka product is designed for food use only and is covered by warranty according to law (art. 1490 and subsequent articles of the Italian Civil Code) for Professional Customers or customers who purchase from the Dealer with a VAT number. The Tecnoeka product is professional and certified according to IEC EN 60335-1 and can only be sold to professional users. With the exclusion of any additional warranty, the Vendor agrees to repair, at its sole discretion, only those parts of the products that prove to be tainted by an original fault as long as, subject to forfeiture, the customer has reported the fault within 12 months from the date of purchase and reported the defect within 8 days from the date of discovery, in writing, attaching a copy of the invoice, receipt or tax receipt as proof of purchase.

Including the event in which the customer is unable to produce the invoice, receipt or tax receipt as proof of purchase, meaning that the terms outlined above are not complied with, the warranty is expressly forfeited in the following cases:

- 1) Faults or breakdowns of components caused by transport.
- 2) Damage deriving from inadequate electrical, hydraulic and gas supply systems compared to that provided in the installation manual, or anomalous operation of these systems.
- 3) Damage deriving from incorrect product installation, or installation not carried out in accordance with the installation manual and, in particular, damage due to the inadequacy of the flues and drains that the product is connected to.
- 4) Using the product for purposes other than its intended use, as specified and resulting from the technical documentation issued by Tecnoeka.
- 5) Damage due to using the Product in a manner that is not in line with the instructions in the use and maintenance manual.
- 6) Tampering with the product.
- 7) Product adjustment, maintenance and repair activities carried out by unqualified personnel.
- 8) The use of non-original spare parts or not authorised by Tecnoeka.
- 9) Damage or defects caused by negligent and/or imprudent use of the product, or in contrast with the instructions set forth in the use and maintenance manual.
- 10) Damage caused by fire or other natural events and, in any case, by unforeseeable circumstances or any other cause beyond the manufacturer's control.
- 11) Damage to components subject to normal wear that require periodic replacement.

Also excluded from the warranty: painted or enamelled parts, knobs, handles, mobile or removable plastic parts, light bulbs, glass parts, gaskets, electronic parts and any accessory parts, transport fees from the consumer, end user and/or buyer's location to Tecnoeka srl, and vice versa. Replacement costs of the oven and relative installation expenses are also excluded from the warranty. The warranty does not cover Products purchased as used or from third parties who are not connected to or authorised by Tecnoeka.

TECNOEKA SRL shall not be held liable for damage, either direct or indirect, caused by a product fault or as the result of the forced suspension of operation.

Repairs under warranty do not result in the extension or renewal of coverage.

Components replaced under warranty are, in turn, covered by a 6-month warranty from the shipping date, certified by the transport document issued by Tecnoeka.

No-one is authorised to change the warranty terms and conditions or to issue others, neither verbal nor written.

9. AVAILABILITY AND SUPPLY OF SPARE PARTS

Tecnoeka srl keeps and ensures the availability of spare parts for a maximum of 24 months from the date of sale of the finished product to the dealer. Availability cannot be guaranteed after said period.

10. APPLICABLE LAW AND COMPETENT COURT

Supply relationships will be governed by Italian law, with the express exclusion of the private international law standards and the Vienna Convention on Contracts for the International Sale of Goods of 11.4.1980. Any dispute will be settled exclusively by the Court of Padua.

Without prior notice and liability for Tecnoeka Srl, the products presented in the manual may be subject to technical and design changes for the purposes of improvement, without affecting the essential features relating to operation and safety. Tecnoeka Srl shall not be held liable for any inaccuracy due to printing or clerical errors affecting instruments, and in the technical and commercial description of its products to customers.



Tecnoeka srl

via Marco Polo, 11 - 35010 Borgoricco, Padova - Italy
Tel. +39.049.5791479 - Tel. +39.049.9300344 - Fax +39.049.5794387

email

info@tecnoeka.com - tecnoekasrl@pec.it

web site

tecnoeka.com