

Food Warmer Cart

User Manual



We will thanks for your support and appreciation with high quality products and services.

This factory mainly produces west kitchen equipments. The series we made are as follows: grill series, fryer series, Barbecue oven series, warming cabinet series, snack series, counter top combination oven series, luxury combination oven series etc.. This dining car of DH series applies widely in school, department, army, hotel and so on.

Brief introduction of function

This series of products are elaborately researched and made by the technicians in our factory, who employ the merits of this kind of foreign and domestic products. The creative and optimized design combined with Chinese special cuisine habits, which have been tested again and again with rigor, approved scientifically and we boldly give up the traditional dress. We pursue to seek truth, creatively employ many excellent practical merit on this series of products, and use high quality stainless steels, accompany with advanced fabrication process, attractive appearance and novel structure, and also they have some qualities which the traditional products can not be compared with.

Before opening it, please read this instruction book carefully to use it correctly.

1. Basic Parameters

Model	Size (mm)	Voltage (v)	Power (kw)	Control switch
HW-11-5F	780*960*1325	220~240V/50Hz	2	1 set
HW-11-21	780*960*1790	220~240V/50Hz	2.2	1 set
HW-22-21	1580*960*1790	220~240V/50Hz	2.62	1 set

2. Transport & Keep

During transport, the products are turning products, so carefully and lightly set them to avoid strenuous vibration. Generally, the wrapped products can not be stored in the open for a long time; you should store them in well-ventilated storehouse where there is no corrosive gas. No inversion .when it needs temporary to deposit, you should adopt water-resistant measures.

3. Safety & Environment

- a) It should be settled at the stable place, apart from the noncombustibilities more than 10cm both left and right. its back should apart from the noncombustibilities over 20cm (such as the wall)

- b) The power-line voltage of this equipment should conform to the nameplate power supply voltage.
- c) The users are needed to set power switch, fuse and creepage protector near the facility. No sundries before the switch, so that you can conveniently handle it .
- d) Before using it, you must apply safety ground .
- e) Before opening it, you should check all the electric elements are stably linked, whether the safety ground is reliable or not .
- f) When changing the power wire, use the same size wire, please ask the professionals to change it.
- g) When install and repair it, you should ask the one with electrician operation permit.

4. Operation

- a) Thermostat is settled in the front, which controls the heating temperature of the heating tube as well as ensure the temperature inside from working tube.
- b) Connected to power, green indicator on, at this time, the power are connected to the equipment, then switch on the temperature controller. Turn it deasil, and turn to the red with your needed temperature. At this time the yellow relay indicating light is on. when the inner container's temperature raises to the needed temperature ,the temperature controller can cut off the power automatically, meanwhile ,the relay indicating light is off and the heating tube stops working. When the temperature reduces slightly, the temperature controller repeat this progress automatically, which can ensure a constant temperature in the inner container. Notice: no set the temperature too high, and usually set it below100°C.
- c) If any unusual phenomenon appears in the progress of using it ,you need to stop using it. Only after carefully check and removal of fault ,you could use it again.

5. Clean & Maintain

- a) When clean and maintain it, cut off the power to avoid accident.
- b) Every time after using it, you can clean the surface of the stove and the stretched wire with wet washcloth, which is without corrosive cleanser.
- c) Don't' clean it straightly with water, if not, you may destroy the electrical performance.

6. Electrical Principle Diagram

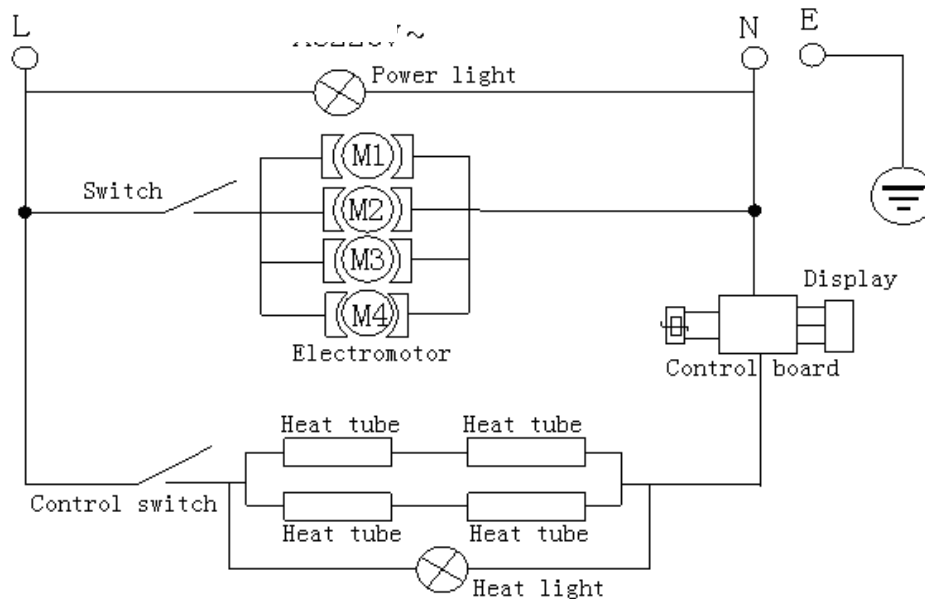

7. Ordinary Fault Treatment

Breakdown appearances	Causes	Solutions
1.turn on the switch ,the indicating light doesn't work	1.the fuse of power switch is broken. 2.power wire is in poor contact	1.replaced the old one with appropriate fuse. 2. secure the power line
2.the yellow light can not be turned off ,so the temperature can not be controlled .	1.indicating lights are wrongly connected . 2.the temperature controller fails to work	1. correct the wires 2.change another temperature controller
3.indicating lights are not lighted and the temperature of the equipment is normal	1.indicating lights are in poor contact 2. indicating lights are broken	1. secure the lines 2.change lights

8. Accessories: A piece of Manual and Certificate of Quality

9. Guarantee Clauses: the product will be maintained for life.

- A. The term of validity for “three guarantee” is: six months
- B. The acknowledgement on the term of validity for “three guarantee”: calculating it from the day of sale, deduct the day of delay ,which results from the repair or without accessories .If the last day of the term of validity is a legal holiday, take the next day of the holiday as the last day of the term of

validity.

- C. Belong to one of the following circumstances, practice reasonable charge for repair:
- a) More than the term of validity
 - b) Have no voucher and note of the term of validity, except those who can prove in the day of the term of validity.
 - c) The content of the voucher do not tally with the product sign or it has been altered.
 - d) Not use the product according to the instruction of usage and maintenance, which result in the damage
 - e) The damage from the force majeure
 - f) The parts being the substitutes of maintain all belong to our factory.
 - g) About the product fault, my plant will not compensate for other obligation which is out of the guarantee.

(The modification of the instruction, please forgive not to notice.)