

VII. Function Introduction

●Start Switch

The switch is preset to "OFF" before delivery. Turn the switch to the "ON" position to start the product. Turn the switch to the "OFF" position to stop the product.

●Pulse Switch

The switch is preset to "OFF" before delivery. Turn the switch to the "ON" position to run the product at full speed. If you release the switch, it will automatically return to the "OFF" position.

●Low/High Speed Switch

The switch is preset to "Low Speed" before delivery. Turn the switch to the "Low Speed" position to run the product at low speed. Turn the switch to the "High Speed" position to run the product at high speed.

●Timer Switch:

The switch is preset to "Stop" before delivery. Turn the switch to the "Start" position to start auto-timing the product.

VIII. Fault Analysis

Fault phenomenon	Cause Analysis	Exclusion Methods
Indicator light is not on	1.The power cord is not plugged in. 2.The stirring cup and the main engine are not assembled properly.	1.Check the power cord to make sure it is plugged in. 2.Make sure that the mixing cup and the main machine are installed properly.
Indicator Light On Product Inoperative	1.Long working hours, motor overheat protection. 2.The machine itself is out of order.	1.Wait an hour before reusing. 2.Send to after-sales service department.

Note:

Above are common trouble analysis and troubleshooting methods. For other troubles, please contact our customer service department, or go directly to our designated repair point for repair. Do not dismantle and repair yourself.

IX. Warning Items

Product in the long-term start-up operation or use in the presence of someone, such as long-term or personnel leave, out of the plug please pull up.

- There are still parts of the standby power on state, due to insulation deterioration or leakage of electricity caused by fire.

Do not spray volatile oils, paints, insecticides on products.

- Can cause electric shocks, fire accidents.

Be sure to pull off the plug when you are not in use for a long time or when you are out of town.

- Some of them are still energized during standby and may cause fire accidents due to insulation cracking or leakage.
- Do not pull off the power cord when pulling off the plug. Always pull it off the plug.

Please make sure to plug in the power cord before use.

- Make sure that the plug fits tightly with the socket. There must be no loosening or incomplete insertion.

Do not trample on the power cord

- Damage to the power cord or socket is the cause of leakage and burns. If the power cord is damaged, it must be replaced by the manufacturer or his service office or a similarly qualified person to avoid danger.

Switch off the power when you are out or sleeping at night

- The utility model can avoid the fire accident caused by the wiring personalization and can save electricity.

Do not allow products to be inhaled or put into combustible substances! And shall not be used where mechanical oil composition floats

- It can cause cracks, odors and fire accidents.

Do not use wet places such as bathrooms.

- Can cause poor insulation. Causing a leakage or malfunction.

Do not use damaged power cords or plugs

- This is the cause of electric shock, short circuit and fire.

Do not use multiple power cord sockets

- Do not overheat or cause fire hazards by using extension cord sockets or sharing power sockets with other electrical appliances.

Do not unplug the power cord with a wet hand

- Do not risk electric shock by unplugging the plug with a wet hand when the power supply needs to be unplugged.

High Speed Blender Operating manual

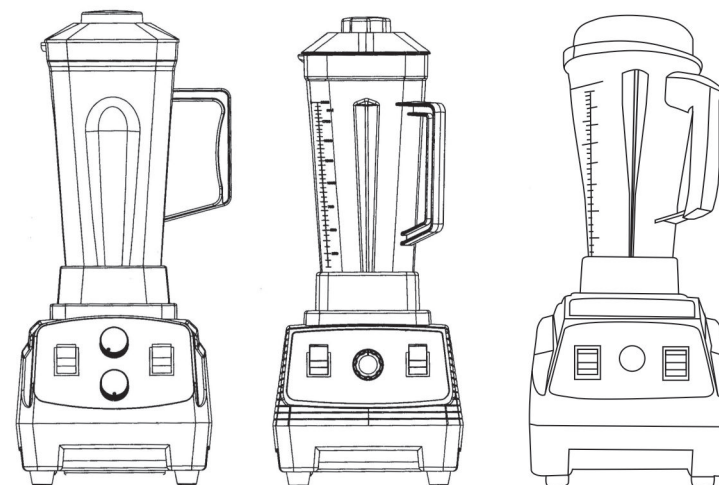

- ◆ Thank you for your trust and support to our products!
- ◆ Please use the corresponding model.
The product is subject to the material object.
- ◆ Please read this manual carefully before use and save it for future reference.

Introduction

Thank you for choosing our High Speed Blender. All the staff of our company will serve you wholeheartedly. In order to use this machine correctly and effectively, please read this manual carefully before using .

I. Major Component Name

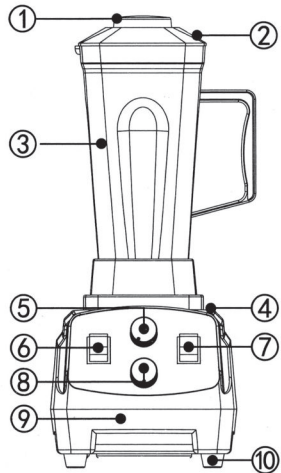

Pictures are for reference only,
please refer to the material object!

- | | | |
|----------------|----------------------|----------------|
| ① steam cap | ② cup cap | ③ mixing cup |
| ④ cup mat | ⑤ speed control knob | ⑥ start switch |
| ⑦ pulse switch | ⑧ timer(optional) | ⑨ base bottom |
| ⑩ rubber feet | | |

The apparatus is intended to be used for domestic and similar applications as than:

- kitchen employees in shops, of \square ce and other work environments;
- farms;
- by clients of hotels, motels and other residential-type environments;
- Bed and Breakfast type environments.

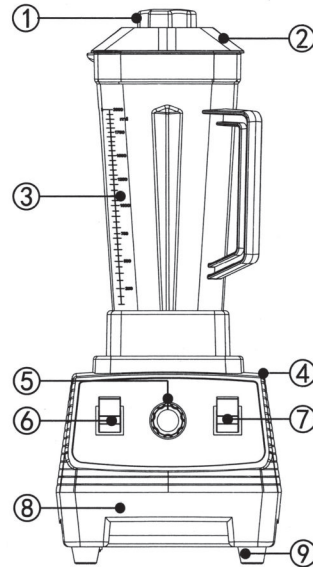

Pictures are for reference only,
please refer to the material object!

- | | | |
|----------------|----------------------|----------------|
| ① steam cap | ② cup cap | ③ mixing cup |
| ④ cup mat | ⑤ speed control knob | ⑥ start switch |
| ⑦ pulse switch | ⑧ base bottom | ⑨ rubber feet |

II. Main Technical Parameters

Rated voltage: : 110-120V/220V-240V ~
 Rated frequency: 50Hz/60Hz
 Rated capacity: 2.0L
 Execution standard: IEC 60335-1, IEC 60335-2-14

III. Points for Attention

- Do not put metal objects such as knives, forks, spoons, etc. into the cup.
- When cleaning, do not clean the knife directly by hand. If you use cleaning tools, please pay attention to safety.
- The contents of the cup should not be too full. Do not exceed two thirds of the capacity of the cup. Please close the lid of the cup when using.
- Before starting, make sure the cup is on the base. It is completely \square xed on.
- Because of the high horsepower, please hold the cup slightly when you start to use it.
- Be sure to cover the cup when using the stirring bar while the motor is running.
- Whether the cup is placed on the table or not. Do not use your hand to fetch food from that cup because the blade is sharp and easy to cut.
- To pour food out, remove the cup from the frame.
- Be careful to touch the switch before and after start-up.
- Utensils cannot be immersed in water.



Care should be taken when handling cutting blades especially when removing blades from containment cups, emptying containment cups, and during cleaning

IV. Safety Matters

- Remember to pull off the plug when not in use.
- Do not lift the lid of the cup until the stirring knife has completely stopped rotating.
- Be sure to separate the frame from the cup when cleaning and make sure to pull off the plug \square rst.
- Do not immerse the motor base in water or put it in the dishwasher for cleaning.
- Keep a proper distance to prevent the child from improper movement and causing danger when the child is not allowed to be nearby during the start-up.
- If the power cord is damaged, it must be replaced by a professional in the manufacturer's maintenance department or similar department in order to avoid danger.

V. Cleaning and Maintenance Methods

- Always pull off the plug when cleaning and maintaining.
- Carefully scrub the cup body and lid with a sponge or cloth and dry.
- Do not put your hand into the cup for cleaning.
- Wipe the rotating shaft and motor base with a dry cloth (remember! Do not rinse with water).
- When it is not easy to wipe, wipe it with neutral lotion, and then wipe it with dry cloth until it is clean.

VI. Circuit Diagram

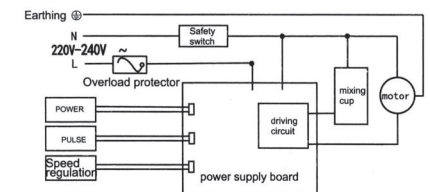

Wiring is subject to change without prior notice