

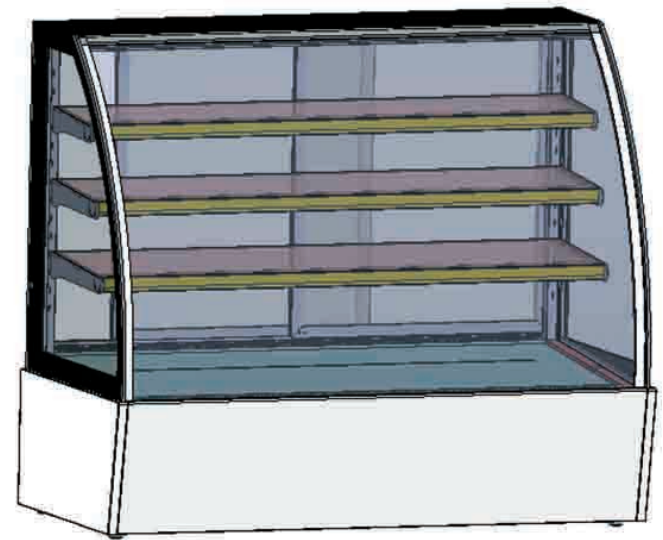

PASTRY SHOWCASE INSTRUCTION BOOK



GUIDE TO THE MANUAL

This manual has been drawn up by the manufacturer and is an integral part of the machine supply. The information it contains is for non-qualified (inexpert) and qualified personnel.

This manual defines the purpose for which the machine was built and it contains all necessary information to ensure its proper installation and safe correct operation.

 Be sure to consult this manual before proceeding with installation, use and any other work on the machine.

Other technical information that is not included in this manual is an integral part of the technical file prepared by EASY BEST and is available at its facilities.

Constant observance of the regulations will guarantee personnel and machinesafety, low-cost operation and a longer operating life.

The careful analysis done by EASY BEST has made it possible to eliminate most risks. be sure to follow all the instructions given in this manual. Always refer to the manual before carrying out any operation. Safeguard this manual and make sure it is always available next to the machine or in the nearby vicinity.

 Before conducting any type of operation, disconnect the machine from electrical mains.

The diagrams and drawings are furnished by way of example. In prusance to its policy of constant development and updating. The manufacturaer may make any changes without giving advance notice.

This manual must be kept for the entire life of the machine. If it is lost or destroyed, a copy can be requested from the manufacturer .Be sure to indicate the data listed on the nameplate (the price will be established by the manufacture).

EASY BEST welcomes any comments from clients concerning improvements to be made on the machine and will assess their implementation.

This document is the exclusive property of EASY BEST and cannot be divulged to third parties. either in whole or in part, without the written authorization of EASY BEST.

EASY BEST reserves all legal rights.

All the measurements listed in this manual are expressed in mm.

CONTENT

1. TECHNICAL DATA.....	3
1.1 TECHNICAL DATA	3
1.2 PAN SHAPE DIMENSION.....	3
2. DISPLAY CASE NAMEPLATES.....	4
2.1 NAMEPLATE POSITION.....	4
2.2 CE MARKING.....	4
2.3 NAMEPLATE OF OTHER COMPONENTS.....	4
3. HOW TO USE AND RESERVE THE INSTRUCTION MANUAL.....	4
3.1 INTENDED USER OF THE INSTRUCTIONS MANUAL.....	4
3.2 OBJECTIVES OF THE INFORMATION IN THE MANUAL.....	4
3.3 HOW TO PRESERVE THE MANUAL.....	4
4. HANDLING AND INSTALLING THE SHOWCASE.....	5
4.1 RECEIVING THE SHOWCASE.....	5
4.2 UNLOADING OPERATION.....	5
4.3 CHECK AND PACKAGE.....	6
4.4 PACKAGE MANAGEMENT.....	6
4.5 PERSONNEL REQUIREMENTS.....	6
5. PLACING ENVIRONMENT FOR DISPLAY AND COMPONENTS INSTRUCTION.....	6
5.1 POSITON NAME.....	6
5.2 APPLICABLE ENVIRONMENT DATA.....	7
5.3 SAFETY REGULATONS DURING USE.....	7
5.4 COMPONENTS INSTRUCTION.....	8
6. CORRECTLY POSITION.....	9

CONTENT

7. DAILY MENTAINCE.....	10
7.1 CALSSIFICATION FOR MAINTENANCE.....	11
7.2 REQUIREMENTS FOR MAINTENCE PERSONNEL.....	11
7.3 CLOTHING.....	11
7.4 CLEANING THE GLASS STRUCTURE.....	12
7.5 CLEANING THE CONDENSER.....	12

TECHNICAL DATA 1

1.1 TECHNICAL DATA

PASTRY SHOWCASE		GN-1200C2 GN-1200R2	GN-1500C2 GN-1500R2	GN-1800C2 GN-1800R2
SPECIFICATION				
External dimentions	mm	1200×730×1200	1500×730×1200	1800×730×1200
Weight (net)	kg	205	245	290
Weight (gross)	kg	---	---	---
Capacity (net)	Liter	305	387	467
		459	580	700
Refrigerant		R134A	R134A	R134A
Refrigeration		Ventilated	Ventilated	Ventilated
Voltage	V/ph/Hz	220-240V/1ph/50Hz	220-240V/1ph/50Hz	220-240V/1ph/50Hz
Climatic class	°C/RH%	30/60	30/60	30/60
Interior temperature	°C	4~10	4~10	4~10
Input power	W	450W	550W	650W

2 THE NAMEPLATE FOR DISPLAY CASE

The nameplate for showcase is mounted on its name, model and range.

Please check to be sure that the instructions manual corresponds to the showcase to which it is referring.

If any information or technical assistance is required, in addition to the model and machine type, you must also indicate its serial number etc.

2.1 LOCATION OF THE NAMEPLATE

The showcase nameplate is located on the rear part (Operator side) PIC-1, the nameplate lists the information that identifies the machine, including its model, serial number and other information.

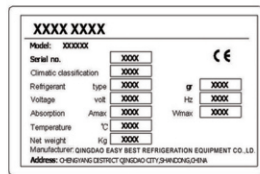
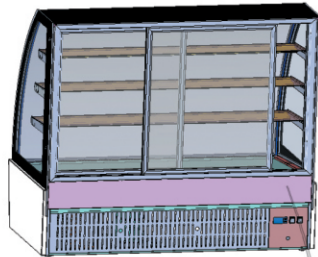

PIC-1

2.2 CE MARKING

The CE mark is applied directly to the nameplate on the showcase.

2.3 NAMEPLATE FOR OTHER COMPONENTS

For the spare parts not manufactured by Qingdao EASY BEST (like compressor and fans), the label is directly on the body of themselves.

3 HOW TO USE AND PRESERVE THE INSTRUCTIONS MANUAL

3.1 INTENDED USER OF THE INSTRUCTIONS MANUAL

This instructions manual is intended for the following personnel.

- Shipping, loading and unloading staff
- Operators
- Installers
- Maintenance personnel

3.2 OBJECTIVES OF THE INFORMATION IN THE MANUAL

The purpose of this manual is to indicate how the machine should be used based on its design. It will also indicate its technical features, offering instructions on how to move, install regulate and use it.

It will also guide you in maintenance work and facilitate spare parts orders.

3.3 HOW TO PRESERVE THE MANUAL

HOW TO USE AND PRESERVE THE INSTRUCTIONS MANUAL 3

We would like to remind the user that the manual must be preserved with care to ensure it will last as long as the machine. Therefore, it is supplied in a special case that can protect it from wearing and tearing over years.

If the manual gets lost or destroyed, a copy can be requested through the firm's area representative or directly from the manufacture. Be sure to specify the type, serial number and year the display case was manufactured.

There is a table PIC-3 on the packing and its purpose is to give detailed production information.

- Dimensions: length width height
- Hoisting hook-up points

Important: Remember that since cardboard packing is used, it is subject to the action of atmosphere (rain, snow). Therefore, the display cases must be stored in a dry indoor area.

4 MOVING, LOADING AND UNLOADING AND INSTALLING THE DISPLAY CASE

The chapter provides the method of loading and unloading, moving and installing the equipment.

4.1 RECEIVING THE SHOWCASE

The showcase has packaging around it to protect it during shipment and/or storage, mainly including of:

Multi plywood pallet

Multi plywood wooden box

Standard package, as is shown in PIC-2

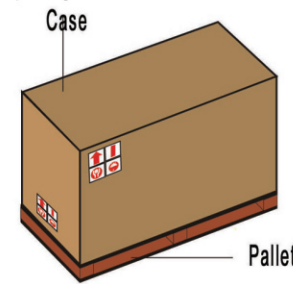

PIC-2

HOIST WITH FORK LIFT



Temporary or extend storage must be done in indoor areas protected from Atmospheric agents. The display cases must be handled with care



4.2 UNLOADING OPERATIONS

The orientation of the packed showcase must comply with the indications listed on the pictograms and the writing on the outside package.

Conduct the unloading operations using suitable hoisting equipment (the capacity must be adequate for the weight of the packed showcase) hoisting it as shown in.

4 MOVING, LOADING AND UNLOADING AND INSTALLING THE DISPLAY CASE

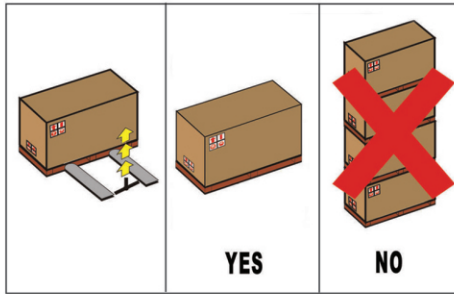

PIC-4

4.3 CHECKING THE PACKAGE

Before taking delivery from the shipper, check the conditions of the packing. If it shows obvious damage on the outside. The display case could be damaged. In this case, unpack the display case in front of the shipper's. Any damage caused by incorrect handling and storage is not the manufacturer's responsibility.

In this case:

- Contact your area representative.
- Show the relevant written report
- Send a copy of the report to The manufacturer or area representative.

4.4 PACKING MANAGEMENT

All the unpacked materials can be recycled in order to dispose of according local legislation. Be sure to destroy plastic components to prevent any hazards (suffocation) to children.

4.5 PERSONNEL REQUIREMENTS

We recommend that the operations to move the display

be handled by personnel accustomed to using hoisting equipment, in full compliance with the safety standards in force.

The showcase can be lifted with a forklift truck or with any other suitable means with a minimum capacity of twice the weight of the showcase (see the specific nameplate).

Operators running the hoisting equipment must remain at an adequate distance from the hoisted part and must ensure that no people or property are exposed to danger if the showcase should drop.

Movements must be slow and continuous to prevent the case room tipping over, etc.

 This chapter offers various general information on the showcase, describing its main functions and use limitation. Damage caused by handling errors are not covered by the warranty.

5 PLACING ENVIRONMENT AND COMPONENT INSTRUCTION OF DISPLAY CASE

The effect of the display case is to keep the temperature of the food and the constant of the relative temperature. Therefore, the food can be put in the case only if it is already cooled and has thus reached its preservation temperature.

5.1 AREAL NAME

No other special technical knowledge is required to use the showcase.

Attentive reading of this manual is sufficient.

PLACING ENVIRONMENT AND COMPONENT INSTRUCTION OF DISPLAY CASE 5

For instance ALBA RANGE ICE CREAM DISPLAY to introduce every area name. Other product is same.

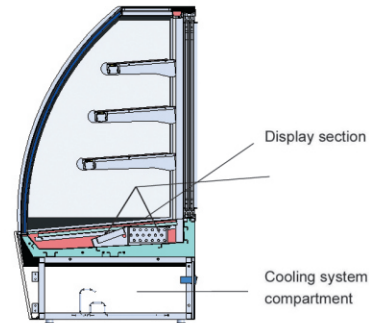

PIC-5

5.2 APPLICABLE ENVIRONMENTAL PARAMETERS

The room or area in which the showcase is to be installed must have the following characteristics:

- Indoors
- Maximum environmental temperature of +30 °C
- Maximum Relative humidity (RH) +60%

5.3 SAFETY PRECAUTIONS DURING USE

To ensure accident prevention, you must read and observe the following precautions before installing the display case and turning it on.

- The latter operation must be carried out exclusively by authorized personnel trained on how to use the display case.
- When this manual discusses switches and other components, it indicates if they are to the right or left of the display case.
- In most situations, the terms "left" and "right" refer to the position of the operator standing in front of the work surface and facing forward (PIC-6/PIC-7).

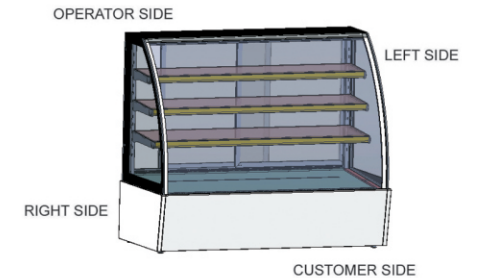

PIC-6

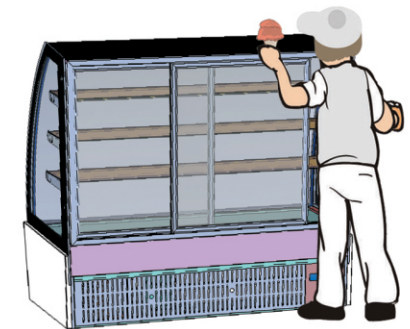

PIC-7

- Never allow anyone to use the display case without proper instruction.
- Carefully read the instructions manual before using the display case.
- Failure to observe use regulations can cause accidents.
- Make sure that each piece of equipment or accessory is installed correctly.

5 PLACING ENVIRONMENT AND COMPONENT INSTRUCTION OF DISPLAY CASE

5.4 COMPONENTS INTRODUCTION

This chapter offer the main component name of the display case and its function. It supplies all the information deemed useful for the operator and maintenance personnel so they can gain a better understanding of correct operation to enable more rapid identification of any fault or malfunctions.

Display section

The display section is the area in the showcase that holds the bubs of food. The model and name for the showcase is different, but their function is same. (PIC-8, PIC-9)

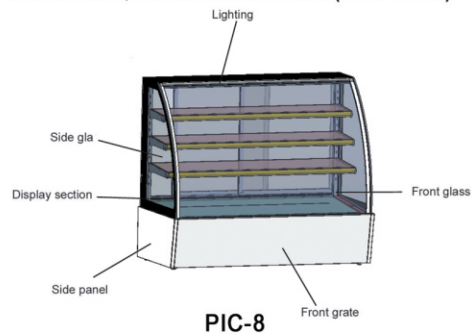

PIC-8

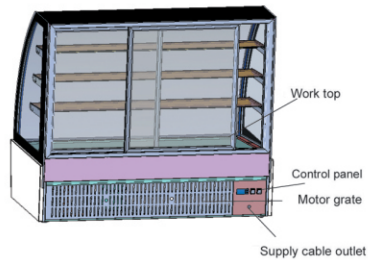

PIC-9

Glass structure

The glass structure is composed of two glass side panels and a front window that makes it possible to

--guarantee the food clean

--protect the contents of the display section from foreign matter.

All the glass can be dismounted simply by removing the screws and the connection bar. We recommend performing these operations with the maximum care, observing the indication listed in the maintenance chapter.

Work counter

The operator side work counter is a continuance of the display section and it is used by the operator as a counter while he is preparing the product to be served.

Motor compartment

The motor compartment is located in the lower section of the display case and all the components required for machine operation are positioned together in a unit referred to the condenser unit.

The main components of the condenser unit are.

- Compressor
- Condenser
- Fan
- Filter

The muter compartment is protected by a iron bracket.

Compressor split and rear grate that are bolted on to ensure maximum safety. In particular during normal operation no one is able to access it an come into contact with live or moving elements. Only qualified technicians are allowed to access it. Observing safety and maintenance regulations. (PIC-10)

Control Panel

The control panel is the element that manages the operation of the display case.

It is composed of the following components: Temperature controller, Power switch, Refrigeration switch, Lamp switch. Etc.

PLACING ENVIRONMENT AND COMPONENT INSTRUCTION OF DISPLAY CASE 5

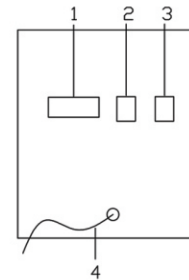

PIC-10

1. Termostat
2. Refrigeration switch
3. Lightning button
4. Power cable

6 THE POSITIONING

This chapter offers all the technical information needed for or installment operations. In accordance with the regulations in force. The installation and test of proper showcase operation must be carried out by qualified personnel in full respect or the regulations in force and of the attached assembly instructions. In the event of installations that do not comply with the recommended installation. EASY BEST declines any responsibility for personal injuries and/or property damage.

The position of the showcase is a very important factor that can compromise proper machine operation. Correct positioning influences the life of the showcase and its components. Above all, however, it affects system operation expenses.

Our technical servicing office can give you any additional clarifications that may be needed.

Using a water level, verify that the showcase is perfectly flat. If necessary, use wooden shims to compensate for any defects in the flooring. (PIC-11)

In order to make sure the showcase will heat dissipation, please do not putting in front of the front grate and the rear grate. (PIC-12)

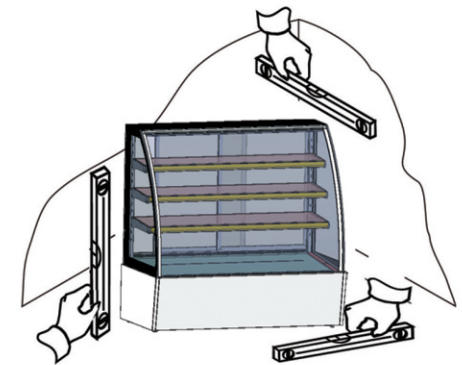

PIC-11

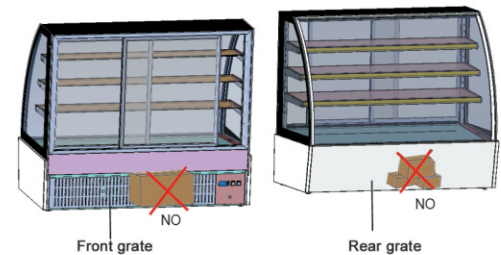

PIC-12

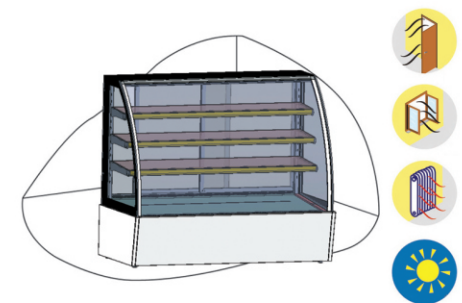

PIC-13

6 THE POSITIONING

Never place the display case hear

- Door
- Windows
- Heat
- Avoid of sunlight

Never place the display case outdoors. Since it may cause unreliable and dangerous for the operator and customers. (PIC-13)

The showcase must be connected to a plug with an omnipolar switch upstream to ensure disconnection from the power mains, there must be some space among the showcase and the obstacle around it in order to avoid any damage after open the front glass. (PIC-14)

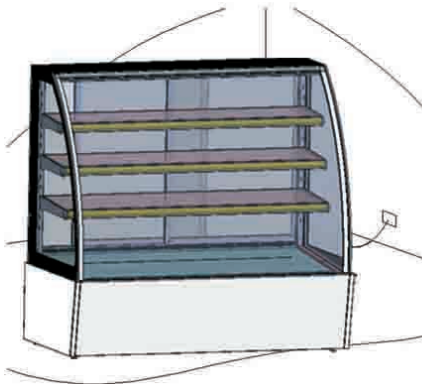

PIC-14

Notice:

- 1) Don't place the power cable in a transit area. We also recommend protecting the cable with trucking anchored on the floor.
- 2) Never touch the power plug if your hands are wet.
- 3) Verify that the power mains network is earthed in accordance with the regulations in force.
- 4) Never insert any adapters or multiple plugs on the s-

upply plug used to connect the showcase.

- 5) Never use extensions to connect the showcase to the mains.
- 6) Verify that the mains voltage complies with the data listed on the name plate of the machine (Maximum allowable variation $\pm 2\%$)



PIC-15

EASY BEST declines any responsibility for personal injuries or property damage caused by incorrect installation.

7 DAILY MAINTENANCE AND MANAGEMENT

This chapter offers all the technical information required to correctly operate and implement the maintenance of the display case.

Before starting any maintenance work or operator checks by himself, you must :

- 1) Verify that the display case is turned off and that it is disconnected from the power.
- 2) Set up a sign for the parts that is being maintained and checked to make a difference.
- 3) If necessary, equipped with adequate lifting equipment.
- 4) Verify the operations to be done will not injure personnel or damage nearby machinery.

SPECIAL NOTE: Although our display case has a relative perfect defrosting system, we still request to defrost weekly. The method is as follows:

1. **Please remove the food before closed.**

DAILY MAINTENANCE AND MANAGEMENT 7

2. Please operate one manual defrost, shut off the power after finished, can remove the frost.

3. Please use warm water to thoroughly clean the pan support; it is very important from hygiene perspective.

4. Please notice that the work bedplate maybe left food, should clean and clear.

5. Please confirm there is no food scraps in evaporator, in case affecting the effect of reducing the temperature.

If the display case has not been used for a long time (as winter season), we recommend the following procedures before turning it on again:

- Thoroughly clean the display section
- Thoroughly clean the condenser
- Thoroughly clean the glass structure
- Thoroughly clean the external structure
- Check the Ventilation fans to be sure weather they can work normally or if there are breakdown.

7.1 CLASSIFICATION OF MENTAINCE

Before starting the display case, must ensure that there are no no packaging pieces and other impurities exist within display case. Before using to clean the display case thoroughly.

1) Normal maintenance: defined as work done to maintain normal operating conditions for the display case, without requiring the replacement of any parts.

This includes:

- Maintenance before the several hours of operation
- Weekly maintenance work

--Monthly maintenance work.

--Work done every six months.

--Work done annually.

2) Extraordinary maintenance: Including the following work:

--Request maintain due to breakdown

--Work to be done at long intervals, i. e. Main parts damaged causing exhibiting didn't work properly.

7.2 REQUIREMENTS FOR MAINTENANCE PERSONNEL

Maintenance of the machine must be conducted solely by qualified personnel specializing in working with refrigerating systems.

They must know and understand the written instructions, laws and regulations and must have had actual training on the operations to be performed.

They must not be drug or alcohol abusers.

A technician who uses prescription drugs must obtain medical advice on his ability to conduct certain types of activities.

7.3 CLOTHING

Before starting any work operation, maintenance workers must wear suitable clothing that respects the indications envisioned by current regulations. All the instruments that are used must be in perfect condition and be checked.



Wear protective gloves

7 DAILY MAINTENANCE AND MANAGEMENT



Wear goggles (during welding wok)



Wear safety shoes



Wear work overalls without any loose ends

3) If not regularly cleaning condenser according to the above request, this quality problem not warranty.(PIC-18)

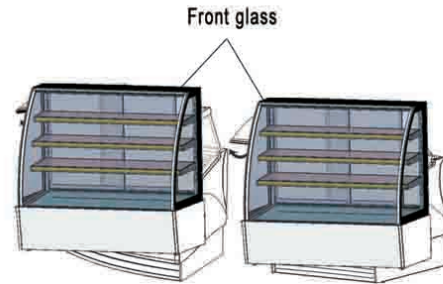

PIC-17

7.4 CLEANING THE GLASS STRUCTURE

Maintenance of the glass structure is very simple but it must also be done carefully due to the type of elements it comprises.

It must be cleaned weekly using warm water.

Note:

- 1) NEVER use inflammable or abrasive products.
- 2) NEVER spray water to clean the display glass.

To clean the display section, you need to remove all the ice cream tubs and place them in the refrigerator. Then you need to open the front glass and clean this section.

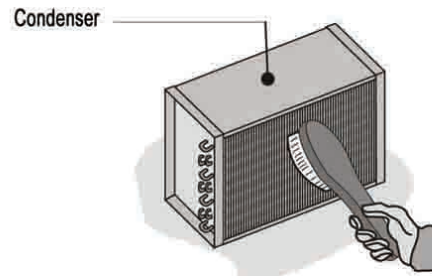

PIC-18

7.5 CLEANING THE CONDENSER

For the protection of the compressor normal effective work, please be sure to regularly clean the dust and dirt on the condenser during 15-20 days.

- 1) Before cleaning, must shut off the power of this part, and shut off the main power.
- 2) NEVER use the inflammable and abrasive products, but can use compressed air or brush.