

Assembly Instructions

Industrial Longspan Shelving

Tools required:

- Hammer or Rubber Mallet.

Recommendations:

- Use a cloth or wooden block to protect components when hammering.
- Hammer gently to avoid component damage.
- Assembly is recommend with two people.

Caution:

- Wear gloves during assembly.
- Handle components with care due to possible sharp corners.
- Assemble the unit on a solid, level surface.

Parts List

A Upright Frame x2 (x1 in Add-On Bay Kit)

C Steel Shelf x 4/8/12

B Beam x8

D Shelf Support x 8/12/16

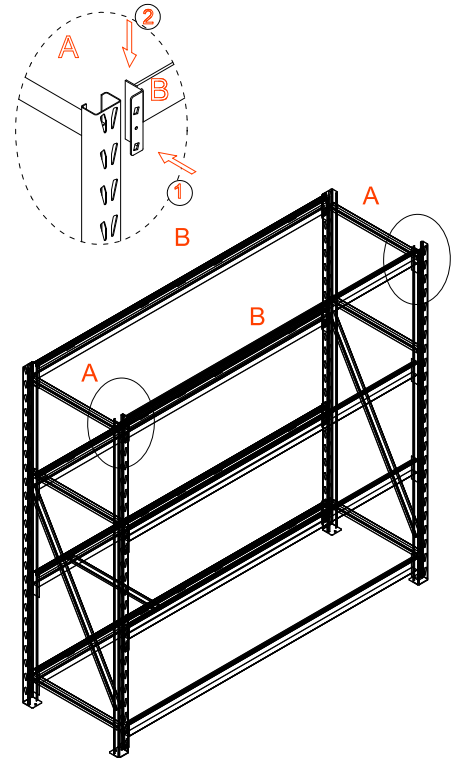
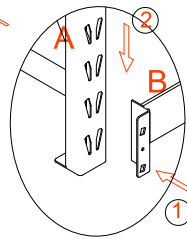
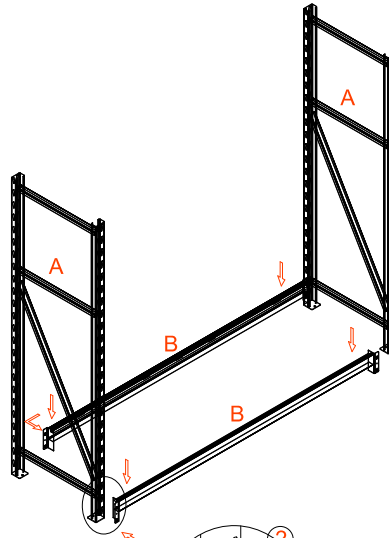
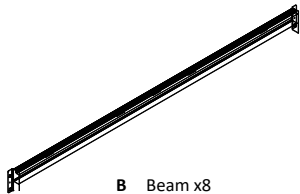
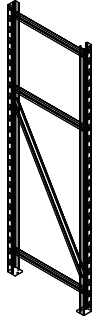

Please read completely through these instructions and verify that all parts are present before beginning assembly.

Step 1 - Join lower beams to uprights per diagram.

Step 2 - Finish beam assembly. Beam height is adjustable.

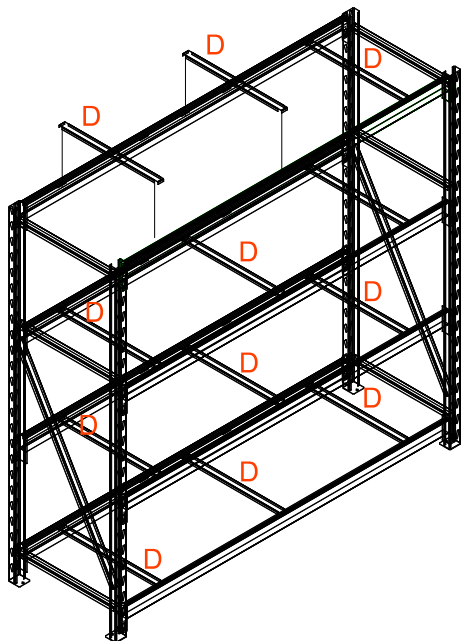

Step 3 - Insert the shelf supports at each level.

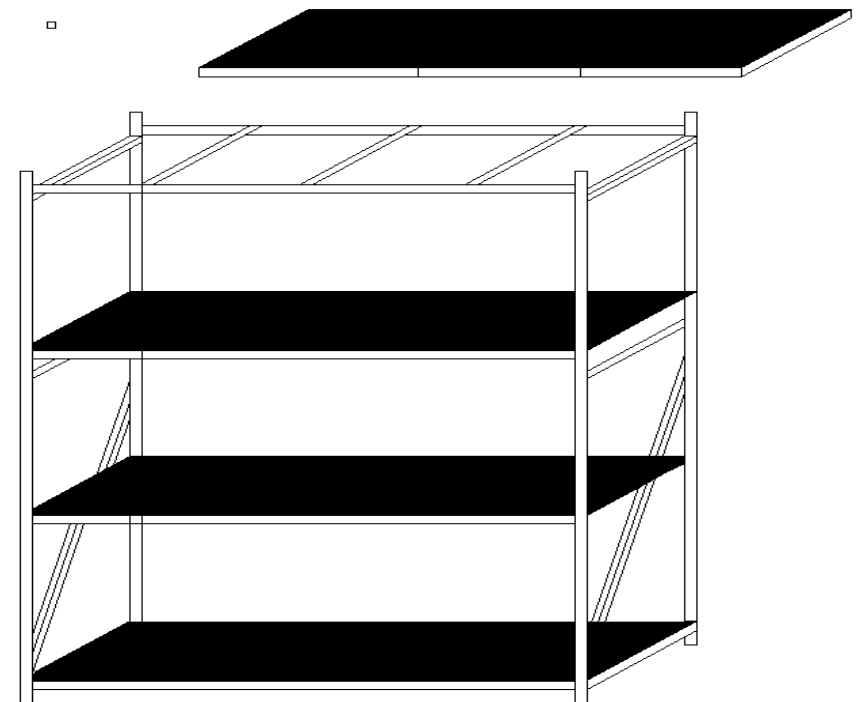

Step 4 - Beginning at the bottom and working your way up, insert the steel shelves.

Step 5 - Complete assembly and move unit into place. For added stability shelving should be anchored to a wall.