

EKL 864 N R

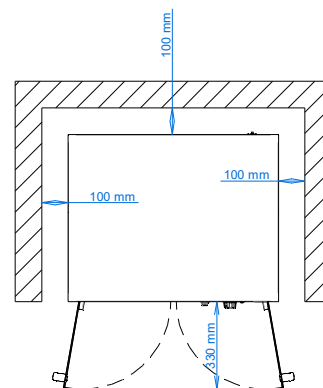

PROOFER WITH WHEELS

The modular design of the EKL 864 R proofer (compatible with the electric convection ovens from the 3- and 4-pan next series), and the fact that it is mounted on castors, give the utmost freedom in terms of space management and operational convenience.

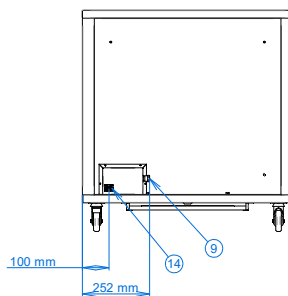
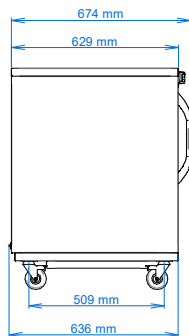
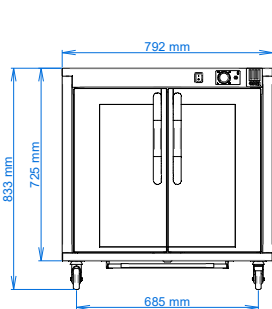

DIMENSIONAL FEATURES

Proofer dimensions (WxDxH mm)	795	655	835
Proofer weight (kg)	45,3		
Distance between rack rails (mm)	70		

ELECTRICAL FEATURES

Power supply (kW)	2,4
Frequency (Hz)	50/60
Voltage (Volt)	AC 220/230
N° of motors	/
Boiler	/
Protection against water	IPX4

EQUIPMENT

Cardboard box dimensions with pallet (WxDxH mm)	845	740	1015
Lateral supports	1 right + 1 left		
Cable	Single-phase [3G 1,5] - L=1400 mm		
Removable drip box			

PLUS

New door
New wheels
IPX4

FUNCTIONAL FEATURES

Power	Electricity
Capacity	N° 8 trays (600x400 mm)
Type of cooking	/
Humidification	/
Proofing chamber	AISI 430 Stainless Steel
Temperature	30 ÷ 60°C
Temperature control	Thermostat
Control panel	Electromechanical – Top side
N° of programs	/
Programmable cooking steps	/
Pre-heating temperature	/
Door	Double leaf

MODULARITY

Ovens	EKF 364 N - EKF 464 N - EKF 416 N series
-------	--