

CE

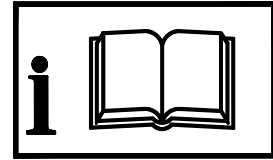

Electric Oven

User Manuals

Model: CP04

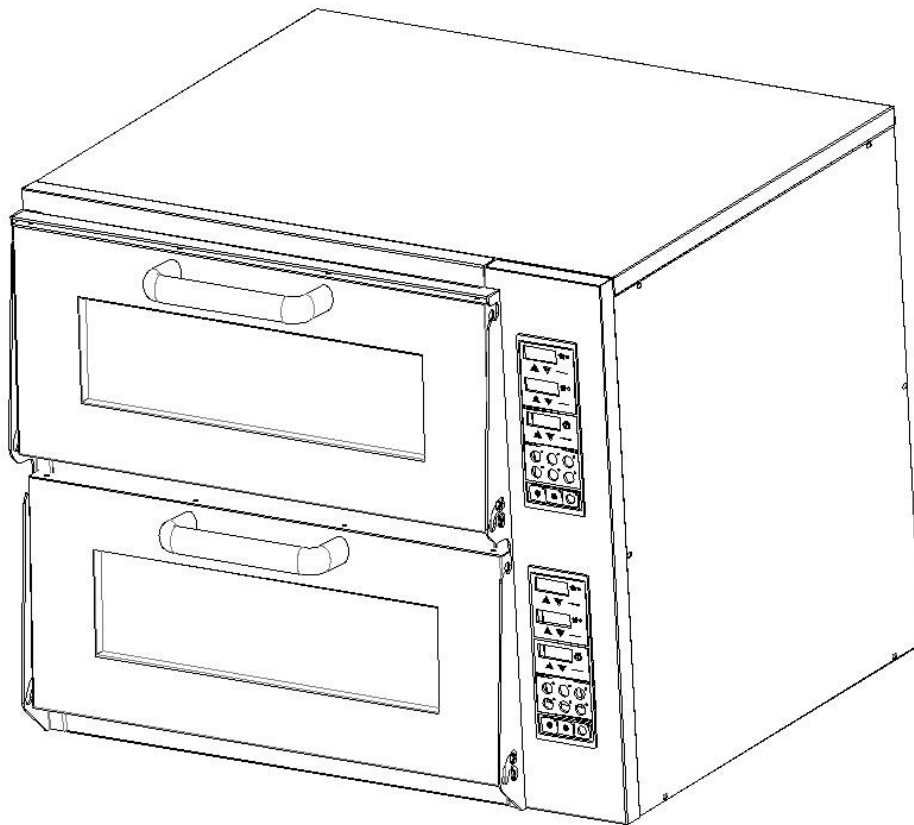

Thanks for your using of our company product, in order to ensure the product performance give full play to the role, please have a read of this manual to reduce unnecessary loss and damage, and get a further study of our product characteristic、installation and operation. Also please keep the manual for further reference.

Index

- I. Safety instruction
- II. Control board operation instruction
- III. Functions
- IV. Machine illustration diagram
- V. Installation instruction
- VI. Operation instruction
- VII. Warning
- VIII. Maintenance
- IX. Trouble shooting
- X. Specification
- XI. Wiring diagrams

I . Safety instruction



Warning:

1. Please confirm the power supply is suitable for the machine using. Also please confirm if the power socket match the power wire parameter.
2. Please use the oven within the limits of the temperature according to the data plate. Also the ground lead must be connected.
3. Don't place any fire goods near the oven, and don't do washing and painting beside the oven.
4. Please prevent other things from dropping inside the oven, which may cause short circuit problem by touching the resistance wire.
5. The power must be put off before open the oven door, also operator can't leave the oven alone when it heating up.
6. Never clean the oven during it working, and never use gasoline to clean.
7. Don't using the damaged power wire, if there are any damaged spare parts, please replace it before using in case of electric leakage.
8. Before cleaning or maintaining the oven, please turn off the power first.
9. Sharing the ground wire with other machine is forbidden.
10. The oven should be installed and maintained by professional electrician.

II. Operating of the digital board

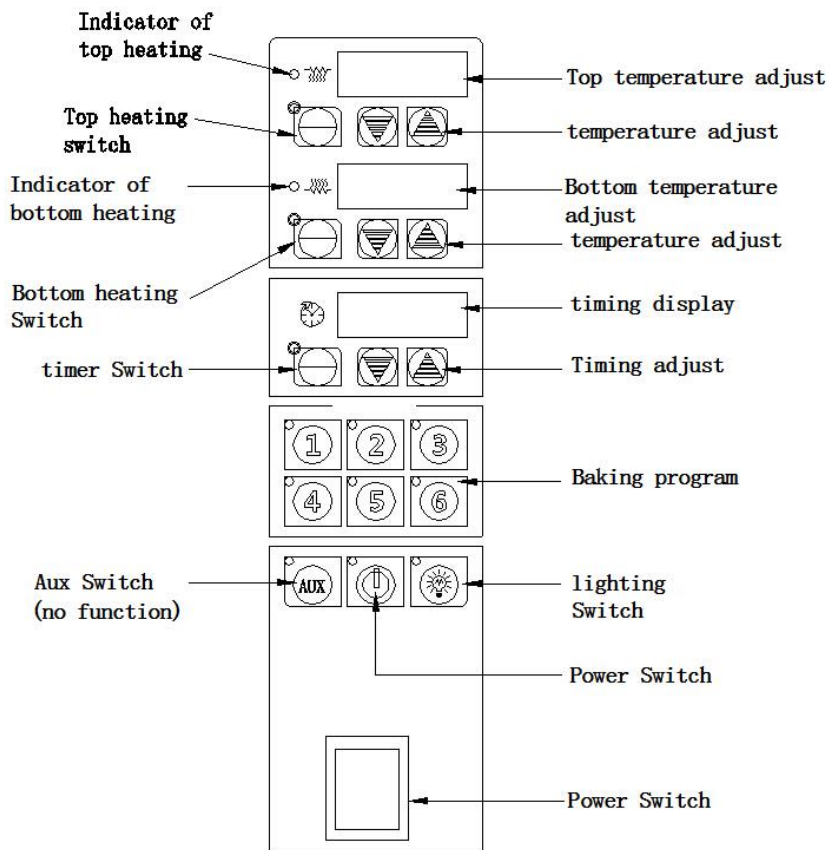

- 1.1 Lighting switch is for controlling the internal light.
- 1.2 Power switch is for starting the digital board.
- 1.3 AUX switch is of no function.
- 1.4 The baking program can preset 6 different programs of temperature and timing for different food.
- 1.5 can adjust the parameter of the temperature or timing.
- 1.6 Timing switch is for controlling the timer.
- 1.7 Time display board is for showing the time.
- 1.8 Temperature display board is for showing the temperature of the top and bottom heating element.
- 1.9 Top heating switch is for controlling the top heating element.
- 1.10 bottom heating switch is for controlling the bottom heating element.

III. Function

1. Functions

- 1.1 Heating up quickly. This oven is equipped with 350°C thermostat, greatly save the cooking time.
- 1.2 Equipped with baking stone, which makes the food are heated more evenly.
- 1.3 Two thermostats separately control the top and bottom heating elements, you can freely adjust the temperature of each heating element.

2. Application

- 2.1 Applicable for baking all the fresh and freeze bread and flour products.
- 2.2 Applicable for baking fresh and freeze meat.

IV. Machine illustration diagram

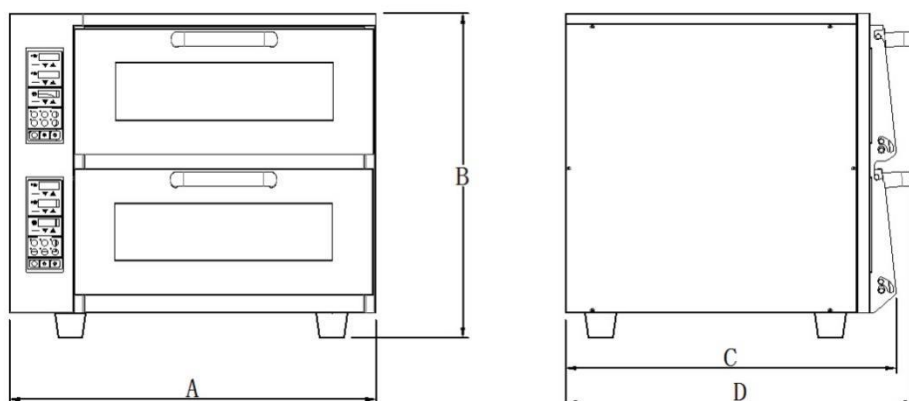

MODEL	A (MM)	B (MM)	C (MM)	D (MM)
CP04	685	630	620	655

V. Installation instruction

1. All the electrical power unit and circuit connection must be installed by qualified electrician with safety standard.
2. Connection must be based on requirement.
3. Make sure the rubber feet have been installed securely.
4. Product should be placed in a well ventilated room on solid platform, and we suggest to leave at least 10cm space between the product and the wall or barriers. Also place the product away from the combustible materials and equipped with fire extinguisher.
5. Remove the packaging film off the surface.
6. The power wire should be connected in accordance with electrical safety standards. Make sure the voltage and frequency conform to the parameter. And please install a double pole switch before connection. When the product working, the voltage error should be under $\pm 10\%$ **(PS: the product must be connected to ground.)**
7. Connect the cable to the power supply fixed by using a screwdriver according to the connection diagram, then loosen the screw inside the power point and plug the cable in, make sure the sheet copper compress the power line tightly. If the connection is incorrect, it may cause joint heating and burning off the power cord.

VI. Operation instruction

1. Turn on the power supply.
 - 1.1 Preheating is necessary before baking food.
 - 1.2 The temperature of the oven can be adjusted between 0~350°C.
 - 1.3 Turn the timer clockwise to the desired time, then the indicator light on and the heating element starts working, when it reaches the set temperature, the indicator light off. If the temperature is below the set temperature, the heating element will be automatically reheated and the indicator light on.
 - 1.4 The internal lighting can help monitoring the baking process.
 - 1.5 Cooking time depends on the amount of the food, the more the food had, the longer the time required.
 - 1.6 Please turn off the power if not using.

VII. Warning

1. If you want to clean、 repair or move the machine, please pull out the plug first.
2. Please don't touch the switch or plug with wet hand.
3. The machine can't be flushed directly, and please be careful don't let the water flow into the switch when cleaning.
4. Keep the children from touching or using the machine.
5. The ground wire must be connected, all the connection must be reinstated after maintenance.

VIII. Maintenance

1. Please pull out the plug first before maintenance, and clean it after cooling down the chamber.
2. For daily cleaning, you can use a dry cloth to wipe off the grease on the chamber, don't flush the chamber with water directly. For cleaning the baking stone, please take out the baking stone, use a fur brush to clean its surface, and rinse it with water then dry it. **(Don't use any cleanser to clean the baking stone, because the baking stone can strongly absorb the water, so that the cleanser would be absorbed at the same time, which may affect the flavor of the food.)**
3. We suggest maintain the machine by qualified electrician once in a month.

IX. Trouble shooting

Stoppage	Solution
Not heating up	<ol style="list-style-type: none">1. Please check whether the connection is loose.2. Rotate the thermostat to your needed temperature.3. Please check whether the power switch is match up with the parameters4. Contact the service center for repair suggestion.
Short circuit	Contact the service center for repair suggestion
Internal light Not work	<ol style="list-style-type: none">1. Pull out the plug, and cool down the chamber.2. Replace a new bulb.
Scorching smell appear	Contact the service center to check whether the connection is short out.
Baking unevenly	Readjust the thermostats for each heating elements to see how they work, If they work well, please contact the service center to check if the Heating element need to change.

X. Specification

Model	Temperature range	Dimension(MM)	Internal dimension(MM)	Voltage(V)	Power (KW)
CP04	0~350 °C	685X655X605	520X500X180	220V	5

XI. Wiring diagrams

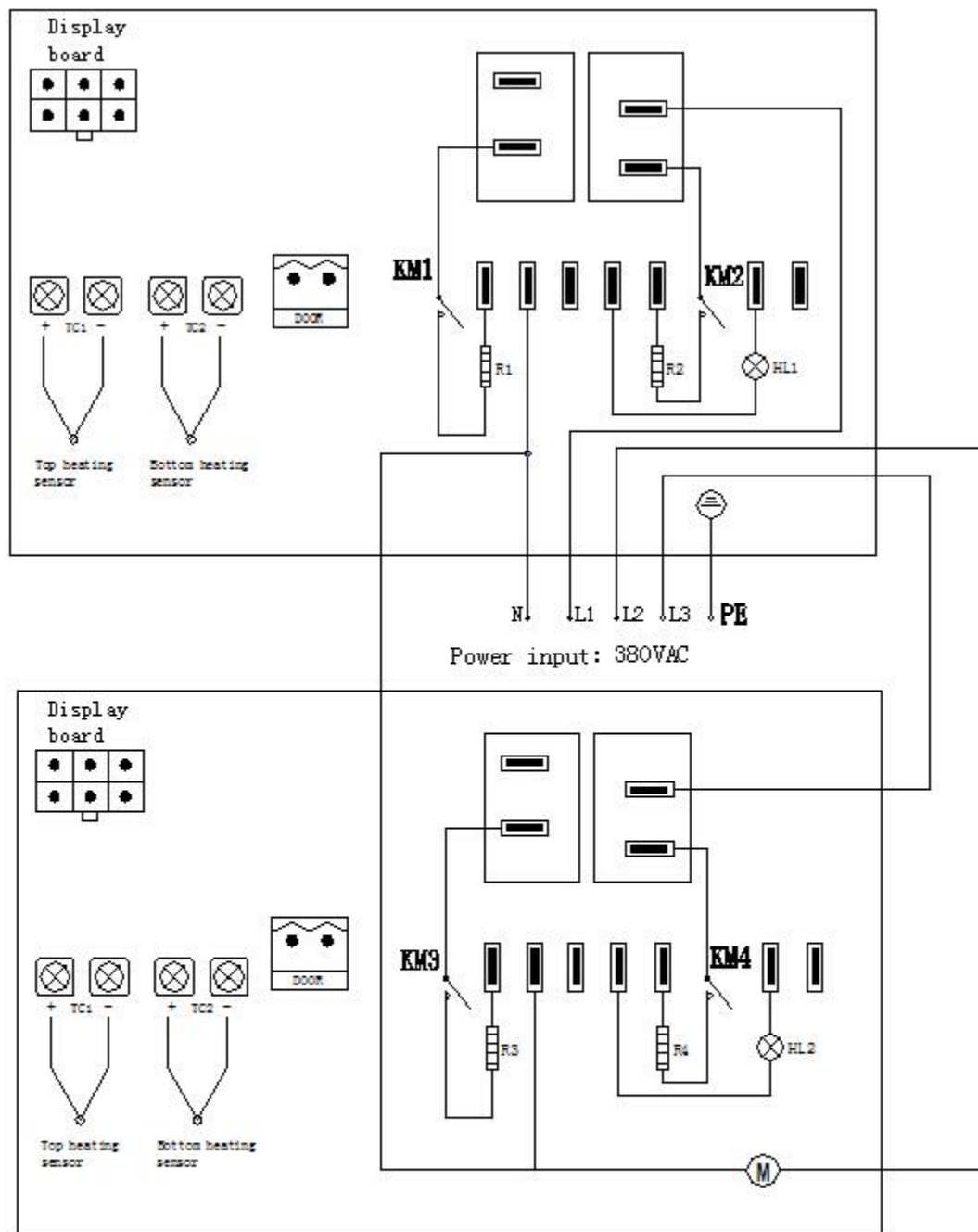

R1 R3-Top heating element R2 R4-Bottom heating element

HL1 HL2 -Internal light

KM1、KM2、KM3、KM4-AC contactor