

**Adexa**

# **BTB-102**

**Fully Automatic Coffee Machine**

User Manual



## CONTENTS





Introduction.....	1	Making Coffee with Milk.....	18
Symbols Used in the Manual.....	1	Clean the Foam Frother Each Use.....	19
Important Safety Warnings.....	1	Making Americano .....	20
Instructions.....	3	Making Hot Water.....	21
Structure Description.....	4	Making Hot Water.....	21
Machine Description.....	4	External Cleaning of the Machine.....	21
Preliminary Examination.....	4	Cleaning Coffee Grounds Tank.....	22
Machine Check.....	4	Cleaning Waste Water Tank.....	22
Machine Installation.....	5	Cleaning the Inside of the Machine.....	22
Machine Connection.....	6	Cleaning of Water Tank.....	23
Use the Machine for the First Time.....	6	Cleaning of Coffee Outlet .....	23
Turn off the Machine.....	10	Cleaning of Brewing Unit core.....	23
Menu Setup.....	10	Descal .....	24
Service Menu Setup.....	11	Tablet Cleaning of Brewing System.....	26
Coffee Pre-brewing Setup.....	11	Tablet Cleaning of Milk Foam System.....	27
Coffee Temperature Adjustment.....	12	Milk Foam System Cleaning.....	29
Buzzer Alarm.....	12	Milk Foam System Automatic Flushing Setup.....	30
Language Setup.....	12	Milk Foam System Rapid Flushing.....	30
Brightness Setup.....	13	Brewing Unit Quick Rinse.....	31
Stand-by Time Setup.....	13	Setting of Water Hardness.....	32
Beverage Parameters and Production Sequence Setting.....	13	Prompt Message .....	33
Factory Default.....	15	General Troubleshooting.....	36
Statistic Information.....	15	Waste Treatment.....	37
Engineering Setup.....	15		
Making Coffee.....	15		
Setting Coffee Strength.....	15		
Setting the Volume of Coffee Cup.....	16		
Adjusting the Thickness of Coffee Beans.....	16		
Tips for Making Hotter Coffee .....	17		
Cancel.....	17		
Making Espresso.....	17		

## Brief Introduction

Thank you for choosing BTB-102 Automatic Coffee Machine. Please take a few minutes to read this Manual before using to avoid causing dangers or damages. Please read these Manual carefully before using this appliance. Failure to follow the Manual for using this machine may result in burns or damages to the electric appliance. The manufacturer is not liable for damages caused by incorrect uses of the appliance. Wish you a pleasant use.

## Symbols Used in the Manual

Important warnings, which must be strictly observed, are indicated by these symbols.

 <b>Danger!</b>	Failure to comply with this warning may lead to electric shock damages and even endanger lives.
 <b>Important!</b>	Failure to comply with this warning may result in personal injuries or damages to the electric appliance.
 <b>Danger of Scalds!</b>	Failure to comply with this warning may lead to scalds or burns.
 <b>Caution!</b>	This symbol indicates important suggestions or information to the user.

## Safety Warnings

### **Danger!**

This is an electrical appliance which may cause electric shock; therefore, you should pay attention to the following safety warnings:

- Please make sure that you can access the socket used by the appliance at any time and unplug the appliance if necessary.
- Unplug the power plug directly; don't pull the power cord in order to avoid damaging the power cord
- Do not make the power cord hanging loosely to avoid tripping or causing damages.
- Do not place the machine or any part in the dishwasher.
- In order to safely and thoroughly disconnect the machine from the power supply, please be sure to turn off the coffee machine through the on/off key firstly and then unplug the power cord from the power socket.
- Don't use the machine if its plug or power cord is damaged, which must and only can be replaced by a technician from any authorized service center to avoid dangers.
- Don't try to repair the machine yourself if it breaks down. Power off, unplug and contact the After-Sales Service Center

- Don't open the covers to prevent fire or electric shocks. User is not allowed to repair the internal parts of the machine by himself; such parts shall be repaired by the authorized service personnel.

- Please turn off the power switch and unplug the power plug before cleaning the machine. Clean the machine after it cools down

- Do not use the coffee machine if it does not work properly or is damaged

- Please do not repair the machine for maintenance without permission

- Do not use a wet cloth to wipe the machine. The water in the wet cloth may enter the coffee machine through the cracks, which may cause electric shock.

### **Important!**

This appliance is not intended for use by persons (including children) with reduced physical, sensory or mental capabilities, or lack of experience and knowledge, unless they have been given supervision or instruction concerning use of the appliance by a person responsible for their safety.

Children should be supervised to ensure that they do not play with the appliance.

If the supply cord is damaged, it must be replaced by the manufacturer, its service agent or similarly qualified persons in order to avoid a hazard.

This appliance is intended to be used in household and similar applications such as:

- staff kitchen areas in shops, offices and other working environments;
- farm houses;
- by clients in hotels, motels and other residential type environments;
- bed and breakfast type environments.

The appliance must not be immersed

The heating element surface is subject to residual heat after use

The coffee-maker shall not be placed in a cabinet when in use

Cleaning and user maintenance shall not be made by children without supervision.

- All kinds of packaging (plastic bags, polystyrene froth plastics) must be kept away from children.

- Appliances cannot be used by persons with reduced physical, sensory or mental capabilities or lack of experience and knowledge unless they have been given supervision or instruction concerning the use of the appliance in a safe way and understand the hazards involved. Children shall not play with the appliance.

- Only normal temperature pure water can be added to the coffee machine tank. It is forbidden to add warm water, hot water or milk and other liquids
- Only roast coffee beans can be added into the bean box of the coffee machine. Do not add coffee ground, chocolate beans, nuts, rice, beans, etc., otherwise it will damage the coffee machine
- If there is burning smell or smoke inside the coffee machine, please unplug the power cord immediately and contact the after-sales service center

#### **Danger of Scalds!**

Hot water and steam may be produced during the operation of the appliance, therefore, please avoid contacting with splashing hot water or steam.

- Please put the machine out of reach of children.
- Some parts of the machine are prone to heating during use. Please do not touch them
- When making fancy coffee, first make sure that the milk suction tube is properly connected to the container, otherwise it is easy to be burned by steam

## Instructions

- This appliance is designed and manufactured to make coffee, milk coffee, hot water and hot milk. The manufacturer is not liable for any damage caused by improper use of the appliance.
- Please store the coffee beans in a sealed and dry place to avoid dampness. If the coffee is not used for a long time, it is suggested to make all the coffee beans left over from the coffee machine, so as to avoid dampness of the remaining coffee beans and blockage of the grinding system of the coffee machine.
- When the machine is in use, if there is a fault, first try to solve the problem according to the prompt message in this manual and the information given in the general troubleshooting. If the problem cannot be resolved, please contact the vendor's authorized distributor.
- Only the manufacturer's authorized dealer or manufacturer's technician can repair the machine. The manufacturer will not be responsible for any consequences caused by the user's failure to comply with the operation guide.
- For repairs, please contact the post sale Service Center

#### **Caution!**

Please take good care of this User Manual. If you transfer the appliance to someone else, please make sure that the coffee machine with this User Manual are delivered to the next user.

## Structure Description

### Machine Descriptions

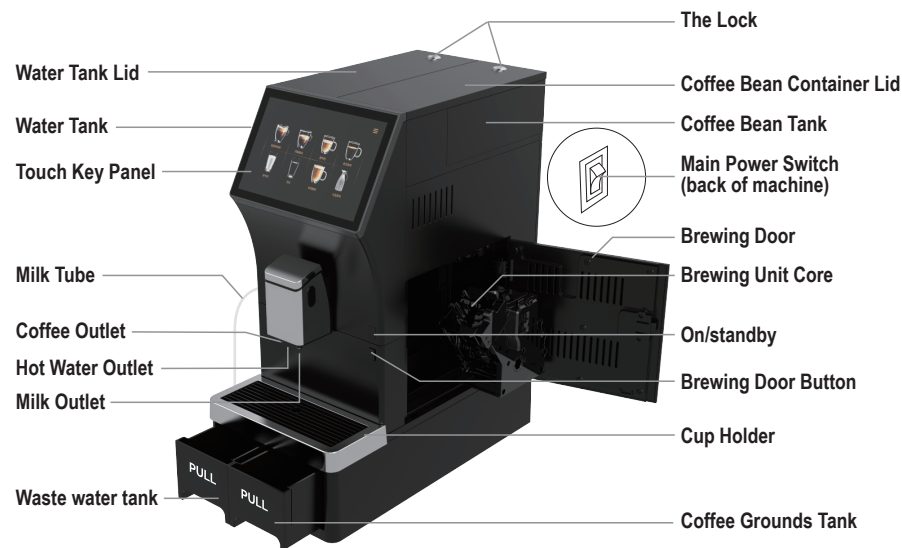

## Preliminary Examination

### Machine Check

After opening the package, confirm that the surface of the machine is intact and not damaged and meanwhile all the accessories are all in readiness. If there is obvious damage in the machine, don't use the machine. Please contact with the after-sales service center.



## Machine installation



machine to the bucket position, then the barreled water is ready to use.

### B. Water supplied by water tank;

(1) Take out the water tank, add fresh water into the water tank until reach the level of MAX, then put it back into the machine;

(2) Turn the knob under the back cover of the machine to the "water tank" position, then it can be ready to use.

3. The machine can discharge the waste water directly through pouring out the waste water stored in Outlet Water-containing Plate after taking it out. Or discharge the waste water into the sink or other containers through the waste water pipe under the back cover of the machine.

### ⚠ Important!

-In order not to affect the filling of water and beans in the coffee machine, the side of the machine and the part against the wall shall be left at least 6 cm space, and the top of the machine shall be left at least 30 cm space.

-If water seeps in, it will not only damage the machine, but also pose a risk of electric shock. Do not place the machine near a faucet or sink.

-Freezing of the water in the machine will damage the machine. Do not place the machine in a place where the room temperature may be lower than 0°C.

-Please choose a place for your coffee machine to avoid excessive temperature and ensure that the heat grille is well ventilated.

-Do not place the power cord on the edge of a sharp material or on a surface in contact with hot objects (such as an electric heating plate), as this will damage the power cord.

## Machine Connection

### ⚠ Important!

Please check and confirm whether the power voltage used is corresponding with the power voltage marked on the name board at the bottom of the machine. Correctly connect the electrical appliance with the power supply with effective ground wire. If the power socket is unmatched with power plugs, technicians with professional qualifications shall replace with the matched sockets.

## Use the Machine for the First Time

### ⚠ Caution!

• Before leaving the factory, the coffee machine will be tested so it is normal to have a little ground coffee in the machine. We guarantee that the machine is brand new.

• Please set the hardness of water as soon as possible according to the contents of chapter "Setting of Water Hardness" involved in this manual.

• Place the coffee machine on the fixed and stable platform and avoid water source.

• Please choose a place avoiding too high temperature for your coffee machine to guarantee radiator grids to be ventilated smoothly.

To start to use the machine, please insert the plug of the power line into the power socket.



1. Add purified water: take out the water tank and fill it to the max line (indicating that the maximum water can be filled) then put the water tank back into the machine (as shown in the figure).

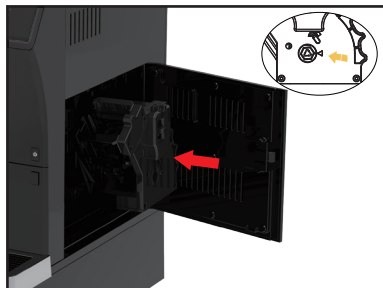

2. Put in the Brewing Unit Core": Firstly, check whether the brewing unit core has been reset to the original position (the two triangle-shaped points should be in alignment, as picture shows), then push the brewing unit core in internal supports and bottom shaft for alignment. Then push in the brewing unit core until hearing "crack" which shows that the brewing unit core is put at the original position (as shown in the figure).



3. Place in drain pans and residue box: place the residue box into the drain pan and then push the drain pan as a whole into the coffee machine (as shown in the figure)



4. Tour in coffee beans: pour coffee beans into the coffee bean container (as shown in the figure). And place a container with the minimum volume of 100 ml under the coffee

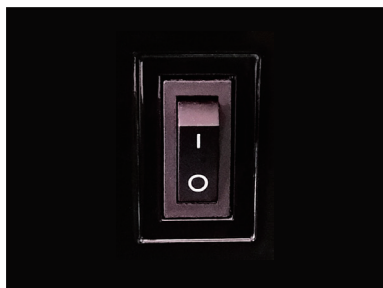

5. After the power is turned on, turn the main power switch on the back of the machine to "I" position (as shown in the figure), and then press the " Q "button to start the machine.



6. Press the blue power button on the right side of the front panel (as shown in the picture above);



7. "Welcome": When the machine is started, the welcome interface will be displayed on the screen.

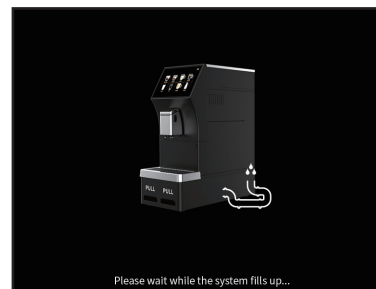

8. "Pipeline Supply Water": when the machine is started for the first time, the display interface is shown as the figure (as shown in the figure).

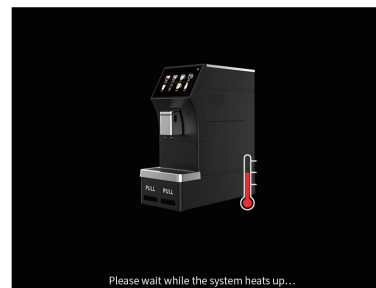

9. "Heating": The machine enters the preheating state, and the display interface is shown in the figure (dynamic display).

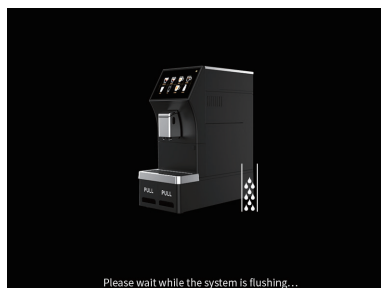

10. "Rinsing": start to rinse internal tubes and waste water will flow out of the coffee outlet after rinsing. The display interface is shown as the figure (dynamic display).



11. After the initial preheating and rinsing, the home page will be displayed then the coffee machine can be started in normal use.

#### Caution!

- When you use the coffee machine for the first time, the noise will be louder than normal as the water supplying pipeline is empty. While the water in the pipeline is replenished, the noise will be decreased.
- When you use the coffee machine for the first time, the satisfactory effect may be reached only after making 3 to 4 cups of Espresso or Cappuccino.
- When we start the machine every time, the machine will automatically complete preheating and rinsing. The process cannot be interrupted and the machine can be used only after finishing the recycling.

#### Danger of Scalds!

In the process of preheating and rinsing, a small amount of hot water will flow out of the double outlets into the outlet water-containing plate under. Pay attention to avoid touching splashing hot water.

## Turn off the Machine

After making coffee every time, if it is not necessary to continuously use, please turn off the machine. First press the cb button on the touch panel, turn off the touch screen and then turn the main power switch at the position "0" and turn off the machine power supply.

#### Caution!

1. Before shutdown, the machine will automatically clean the coffee pipeline. If fancy coffee has been made, the machine will remind you to clean the milk tank after automatically cleaning the coffee pipeline. Please operate as "Clean the Foam Frother Each Use" section.
2. If the machine is not used for a long time, please unplug the power cord of the machine.

#### Important!

To avoid damaging the coffee machine, please do not turn the power switch to the "O" position under the state of starting the coffee machine.

## Menu Set

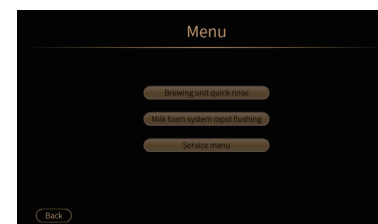

Press the "≡" icon in the upper right corner of touch panel and enter the menu setup program. Press the item you required. If it is required to exit the menu program, please press "Return" to exit the program (as shown in the left figure). There are menu items to be chosen: Quick Rinse of Brewing Unit Core, Quick Rinse of Froth Maker, Service Menu.

**⚠ Caution!**

Note: The initial password for the service menu : 123456

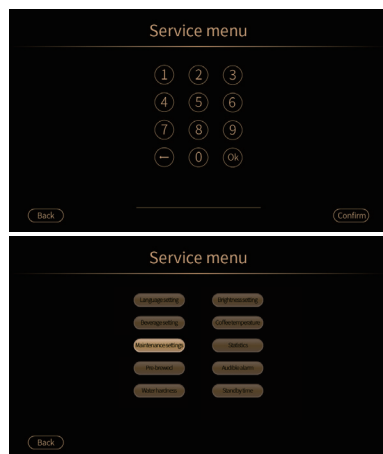
**Service Menu Setup**

Press the "≡" icon in the upper right corner of the touch panel to enter the menu setup program. Press "Service Menu", enter password to set the program.

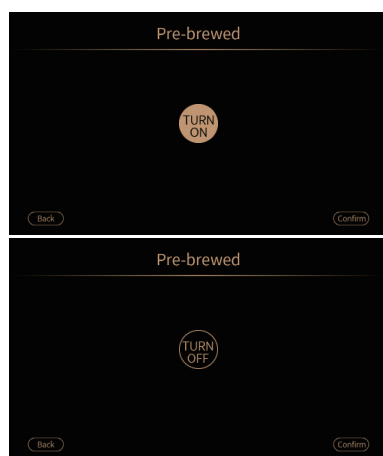
**Coffee Pre-brewed Setup**

Press the "≡" icon in the upper right corner of the touch panel to enter the menu setup program. Press "Service Menu", enter password and confirm.. Press "Service Menu — Pre-brewed" to enter into "pre-brewed" menu. (ON means turning on the pre-brewed function while OFF means turning off the pre-brewed function). If it is required to exit the program, press "Back" icon to exit the program.

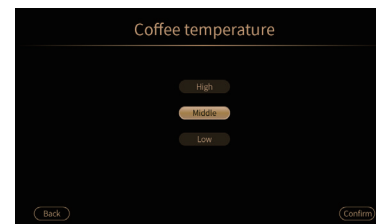
**Coffee temperature Setup**

Please set up the temperature of making coffee as follows: press the "≡" icon in the upper right corner of the touch panel to enter the menu set up program, enter the password and confirm. Press "Service Menu → Coffee Temperature" to enter Coffee Temperature Adjustment menu And select "high", "medium" and "low" as required. If it is required to exit the program, elect "high", "medium" and "low" as required. If it is required to exit the program, press "Return" icon to exit the program.

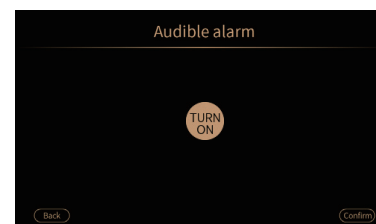
**Buzzer Alarm**

When the machine is in abnormal operation state, the coffee machine enters alarm interface to display related faults and the "alarm" will ring. If you want to turn off the Kalarm sound", please operate according to the following steps: press the "≡" icon in the upper right corner of the touch panel to enter the menu set up program. Press "Service Menu", enter the password and confirm. Press "Service Menu → Audible alarm." Choose "On" or "Off" according to your needs. If it is required to exit the program, press "Back" icon to exit the program.

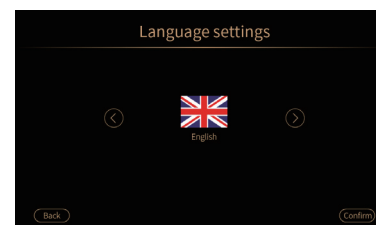
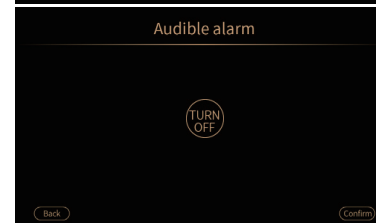
**Language Setup**

Press the "≡" icon in the upper right corner of the touch panel to enter the menu set up program. Press "Service Menu", enter the password and confirm. Press "Service Menu → Language Setup" to enter into "Language Setup" menu, and choose "<" and ">" according to your request. Press confirm to complete. If it is required to exit the program, press "Back" icon to exit the program.

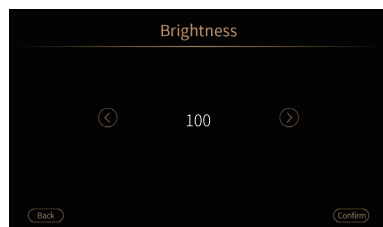

## Brightness Setup

Please set up the brightness of coffee machine according to the following steps: Press the "≡" icon in the upper right corner of the touch panel to enter the menu set up program. Press "Service Menu", enter the password and confirm.

Press "Service Menu → Brightness Setup" to enter into "Brightness Setup" menu, select as required and then press confirm to complete. If it is required to exit the program, press "Back" icon to exit the program.



## Standby Time Setup

The factory setup of the machine is that the machine will automatically start cleaning and then enter standby mode if not used continuously for 60 minutes. You can set to turn off the machine automatically 30 minutes, 45 minutes, 60 minutes, 2 hours, 3 hours, 4 hours and 5 hours after using it.

Press the "≡" icon in the upper right corner of the touch panel to enter the menu set up program. Press "Service Menu", enter the password and confirm. Press "Service Menu → Standby Time" to enter into "Stand-by Time" menu. Select the required standby time and then press "confirm" to complete the set up. If it is required to exit the program, press "Back" icon to exit the program.

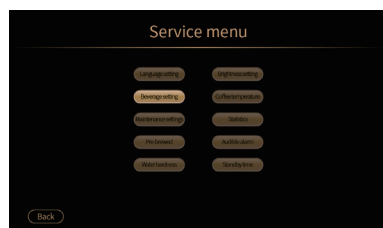

## Beverage Setting

Press the "≡" icon in the upper right corner of the touch panel to enter the menu set up program. Press "Service Menu", enter the password and confirm. Press "Service Menu → Beverage Setting" to enter into "Beverage Setting" menu.

Press the beverage icon you need to change, then set the parameters on the right side of the icon, and press "confirm" to complete the setting. If it is required to exit the program, press "Back" icon to exit the program.

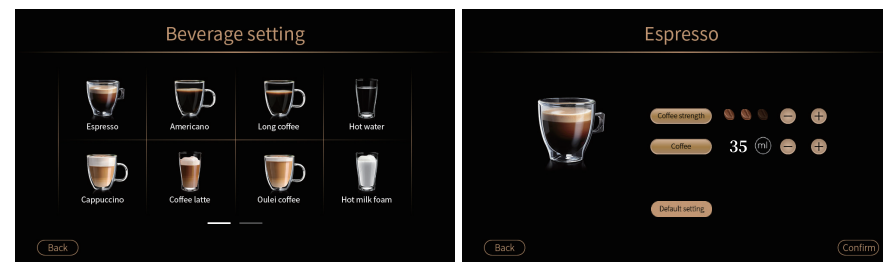

### Example 1:

Set the parameters of Espresso, the coffee concentration is two beans, and the coffee volume is 35ml.

Follow the above steps, select "Espresso" (as shown in the figure), enter the parameter setting of Espresso, select the coffee concentration and coffee amount (as shown in the figure) by "+" and icons, and then press the confirm key to complete the Espresso volume setting of 35mL.

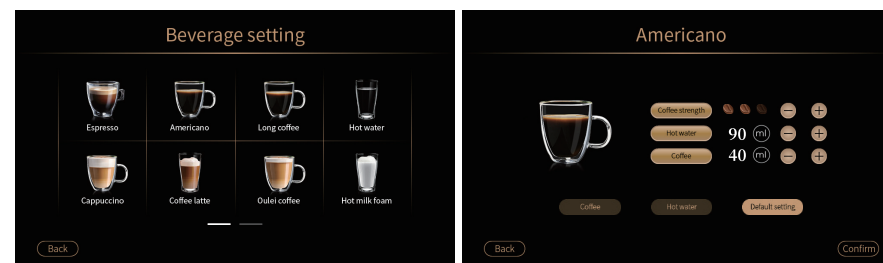

### Example 2:

Americano production sequence Settings.

According to the above steps, select "Americano" (as shown in the picture), enter the parameter setting of Americano, and click the order of drink formula to determine the order of drink production. For example: click "hot water" and then "coffee" and press the "Confirm" button to complete the setting, then the production sequence is hot water first and then coffee.

## Factory Default

When you choose the program, all the menu program setup will resume to the setup when leaving factory as below:

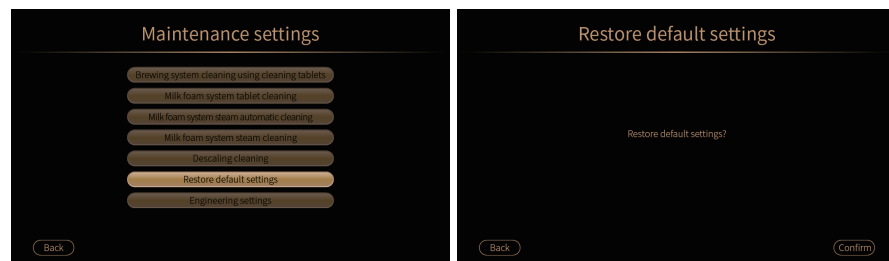

Press the "≡" icon in the upper right corner of the touch panel. Press "Service Menu", then enter the password and confirm. Press "Service Menu → Maintenance → Factory Default" to enter into "Factory Default" menu. Select "yes", then press „confirm,, to complete (as shown in the figure).



## Statistic Information

Under this menu you can find information about this coffee machine. If need, please check according to the following steps:

press the "≡" icon in the upper right corner of the touch screen. Press "Service Menu", enter the password to enter the setup program. After choosing the icon "Statistic Information", you will find how many cups of each coffee.

## Engineering Setup

Engineering Setup is for password protection. This section can only be operated by maintenance staff after entering the password.

## Making Coffee

### Setting Coffee Strength

The factory setting of the coffee machine is defaulted to standard strength. You can choose your favored strength through setting up in KBeverage SettingH program.



## Setting the Volume of Coffee Cup

You can set the coffee volume according to the section of "Beverage Parameters and Production Sequence Setting".

## Adjusting the Thickness of Coffee Beans

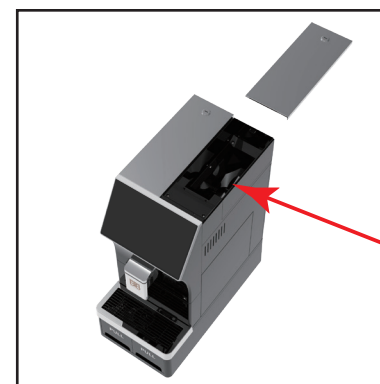

The grinding system regulator is in the bean box. Please open the bean box cover and adjust it while it is in operation

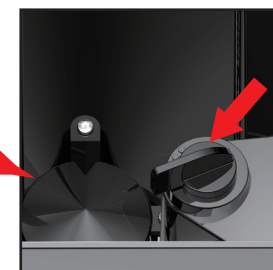

This machine is a very professional barista, can bring you a cup of mellow, fragrant, delicious coffee. Please do as follows:

1. Machine factory Settings → middle-grade (Suitable for medium roasted coffee beans).
2. If the coffee is produced too quickly and is too weak, it means that the coffee powder is too coarse. When the grinder is running, please adjust the knob (as shown in the picture) counterclockwise one step at a time until the desired effect is achieved.
3. If the coffee is too slow or too strong, it indicates that the coffee powder is too fine. Please adjust the knob clockwise (as shown) one grid at a time when the bean grinder is operating until you achieve the desired effect.
4. Tips: According to your coffee beans roasting degree adjustment, depth coffee beans please adjust clockwise, light coffee beans please adjust counterclockwise, until you achieve the desired effect.

## Tips for Making Hotter Coffee

Here are some suggestions for making a cup of hotter coffee:

- Before making coffee, press the "≡" icon in the upper right corner of the touch panel, enter the menu set up program, and select "Quick Rinse of Brewing Unit Core" to make a cleaning cycle;
- Wash the coffee cup with hot water to make it warm (use hot water function).
- Set the coffee temperature to a higher temperature in the menu.

## Cancel

This machine can be pressed "Stop" to cancel the function in the process of making drinks.



## Making Espresso

For example: Make 1 cup of espresso

1. Click the "Espresso" coffee, and the coffee machine starts to make it (as shown in the picture);
2. During the beverage making process, you can click "Stop" to stop the coffee making;
3. The coffee outlet should be as close as possible to the coffee cup (adjust the height of the coffee outlet), which will make the coffee oil richer and the temperature more stable;
4. A cup of Espresso is automatically produced.

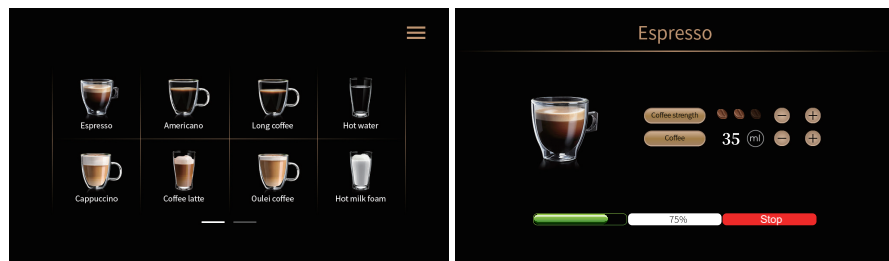

## ⚠ Important!

- If the coffee flows drop by drop, not strong enough or not rich in crema, or the temperature is too cool or hot, etc., please refer to the description in the troubleshooting section of this manual for details.
- During the process of using the coffee machine, various warning messages will be displayed on the screen. Please refer to the chapter "Prompt Message" in this manual for details.
- If the coffee machine has not been used for three days, it is recommended that all the coffee beans left in the coffee machine shall be produced, to prevent the remaining coffee beans from being wet due to the weather, causing the damage of coffee machine

## Making coffee with milk

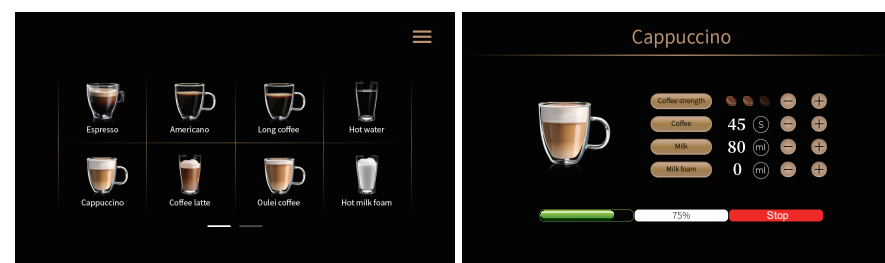

For example: Making cappuccino

1. Click on "Cappuccino" coffee to start making coffee (as shown)
2. During the beverage making process, you can click "Stop" to stop the coffee making;
3. The coffee outlet should be as close as possible to the coffee cup (adjust the height of the coffee outlet), which will make the coffee oil richer and the temperature more stable;
4. A cup of Cappuccino is automatically produced.

## ⚠ Caution!

If you need to make a rich milk froth, please use the refrigerated whole milk (about 5 °C). In order to avoid less or much milk froth, please press the "Clean" function key on the touch panel to clean the machine after making the coffee containing milk, and then often clean the milk froth maker cap and steam hot water nozzle according to the chapter "Milk Foam System Cleaning" in the Manual.



## Clean the Foam Frother Each Use

### Danger of Scalds!

When cleaning the inner tube of the milk container, there will be hot water flowing out of the milk outlet. Please avoid contacting the splashing hot water. After making milk every time, it must be cleaned to remove milk residues.

Please follow the steps below:

1. Insert the suction tube into the container with water.
2. Place one cup or other container under the froth outlet.
3. Press the "☰" icon on the touch screen to enter the menu setting program. By pressing "Service Menu", enter the password, and press "Confirm" key. Click "Service menu → Maintenance Settings → Milk foam system cleaning" option to enter the milk foam system cleaning program, Then the steam line is cleaned automatically. It is recommended to wash several times to ensure that the raw milk residue is washed away.

### Caution!

1. If you need to make many cups of milk-containing drinks, clean them after making the last cup.
2. When manually turn off power by pressing the touch panel, if fancy coffee or milk has been made, the machine will enter two cleaning modes. When without milk tank, machine will directly into the milk foam system cleaning, please follow the steps below:

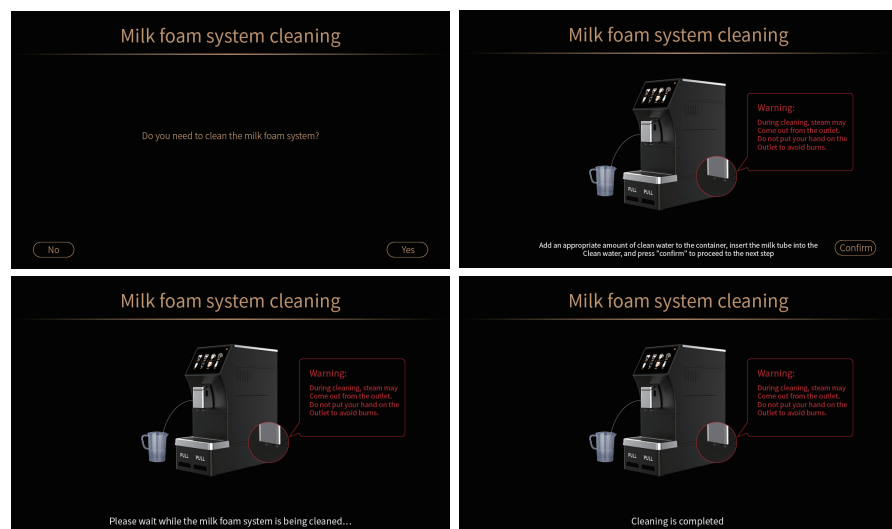

- ① Place one cup or other container under the milk flow outlet;
  - ② Pour some water in the container, then insert the milk tube into the water. Adjust the knob to milk froth position and press "confirm" to proceed to next step.
  - ③ The screen will show "" Milk foam system cleaning " (as shown in the figure). And Then Press the Confirm Key", the machine will start cleaning the steam pipeline, and it will automatically turn off after cleaning;(turn into standby mode).
3. The machine will automatically start rinsing when it is activated and turned on. And the screen will remind "Do you need to clean the milk foam system" after rinsing. If you press "Yes", then you will enter the cleaning of milk froth system, the steps are same as the above Step 2. After cleaning, the machine will go back to home page. If you choose KnoM, then you will go directly to the home page.

### Danger of Scalds!

While cleaning the milk tank, be careful of the steam from the milk outlet, and pay attention to the risk of scalding.



## Making Americano

1. Select the volume of coffee cup and strength according to personal taste, the same as the program for making Espresso.
2. Press  on the touch panel to make Americano.
3. The machine starts to work. At this time, the coffee cup volume and strength will be displayed on the screen display. At the same time, the cup on the screen will display the production progress (dynamic display).

### Caution!

If you want to stop making coffee midway, press the "Stop " icon to stop the release of milk or coffee.



## Making Hot Water

### Danger of Scalds!

Do not make hot water or steam unattended. When making hot water, the hot water and steam nozzles will become very hot. Please take the cup through the handle of the cup.

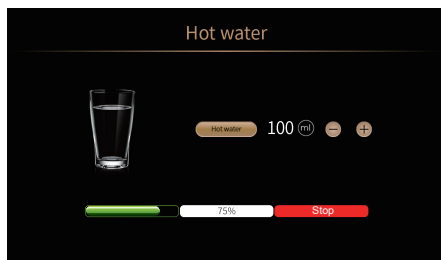

1. Place a container under the hot water outlet (keep the coffee outlet as close to the cup as possible to avoid hot water splashing).

2. Press the  icon on the touch screen to start making hot water.

3. The machine begins to release hot water and then automatically stops, while the display shows a progress bar for releasing hot water. To manually stop the release of hot water, press the "Stop" icon.

## Cleaning

### External Cleaning of the Machine

The following parts need to be cleaned regularly:

- Coffee Grounds Tank
- Waste water tank
- The inside of the machine. After opening the brewing door, there are available parts.
- Water Tank
- Coffee Outlet
- Brewing Unit Core
- Touch Key Panel

### Important!

Do not use detergents or alcohols of dissolving capacity and abrasiveness to clean the container, the chemical substances shall not be used for cleaning; Never use a metal object to remove stains from the coffee machine. This can scratch the metal or plastic surface of the machine.



### Cleaning Coffee Grounds Tank

When the coffee grounds box is full (20 grounds), the display screen will show it. It shall be emptied and cleaned, otherwise the machine will fail to make coffee. To pull out the outlet water-containing plate to take off the coffee grounds tank. Empty the tank and clean it. The cleaning brush can be used to empty the coffee grounds tank and thoroughly clean the residues.

### Important!

After removal of the outlet water-containing plate, the coffee grounds tank must be emptied, even the residues is of small amount; otherwise, when you continue making the coffee, the coffee residues may possibly exceed the height of the bottom of the coffee grounds tank, resulting in blocking the operation of the machine.

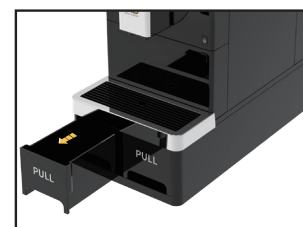

### Cleaning Waste Water Tank

If the waste water tank is not emptied regularly, water may overflow from the edge and then penetrate into or around the machine, which will damage the machine and the table top or around the machine.

Pull out the waste water box (as shown) on the front of the machine, empty and clean the waste water box, and push the waste water box back to the original position.

## Cleaning the Inside of the Machine

1. The cleanness of the inside (all the places can be touched after removal of the water pan) of the machine shall be checked regularly (after making 100 cups of coffee every time). If necessary, the coffee sediments can be removed with the brush or the sponge.

2. The residues can be removed with the vacuum cleaner.

### Danger!

Before the cleaning for the inside of the machine, please power off the machine firstly. Please refer to the details described in the section of "Turn off the Machine" and unplug it. The machine shall not be immersed in water.

## Cleaning of Water Tank

It shall be cleaned monthly and the specific operating steps are as follows:

- 1.To remove the water tank.
- 2.The water tank can be cleaned with the wet cloth and the mild detergent and washed with the running water.
- 3.After clean washing, to pour the pure water into the water tank and put it back to the machine.

## Cleaning of Coffee Outlet

- 1.The coffee outlet shall be cleaned with the sponge or cloth.
- 2.The blocking of the small holes of the coffee outlet shall be checked. If necessary, they can be cleaned with the toothpicks.

## Cleaning of Brewing Unit core

The brewing unit core shall be cleaned once a month at least.

### ⚠ Important!

The brewing unit core cannot be removed when the machine is on. It can only be removed when the machine is in resetting mode.

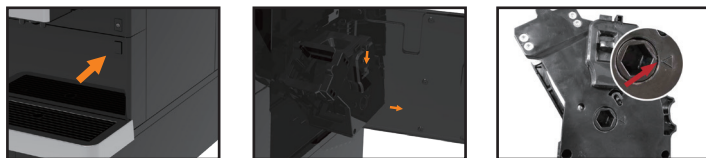

- 1.The machine shall be shut down correctly (please refer to the details in description of Section of "Turn off the Machine").
- 2.To press the locking button of the brewing door to bounce off the coffee brewing door, (as shown in Figure 1).
- 3.To pull and hold to release the button downward. Meanwhile, to pull out the brewing unit core and remove it. (as shown in Figure 2).
- 4.To put the brewing unit core in the water to have it immersed for about five minutes and then wash it with water.
- 5.After cleaning, please check whether the brewing core has been restored to the position (as shown in figure 3). If it is not aligned, gently shake the brewing core to the right to restore it to the original position.
- 6.After finishing cleaning, to push the brewing unit core into the internal bracket and align it with the bottom shaft, then to push the brewing unit core in. A cracking sound will be heard and it means that the brewing unit core has been put back in place., and close the brewing door of the coffee machine.
- 7.Put the brewing core back in place, make sure the release button locks the brewing core and close the brewing door of the coffee machine

### ⚠ Important!

The brewing unit core shall be cleaned with the water, not the dish-washing machine. Do not use the detergent to wash the brewing unit core to prevent damage.

### ⚠ Caution!

If it's difficult to put the brewing unit core back to the machine, the brewing unit core can be gently shake to make it suitable to the correct size.

## Descale

### ⚠ Important!

The cleaning tablet contains the acidic materials irritating to eyes and skin. The safety warning marked on the packaging of the cleaning media by the manufacturer shall be strictly followed. In case of inadvertent contact with the eyes and skin, the relevant steps should be followed.

### ⚠ Danger of Scalds!

During the descaling, the hot water with cleaning solution will flow from the hot water outlet and please avoid the scald injury by the splashing hot water.

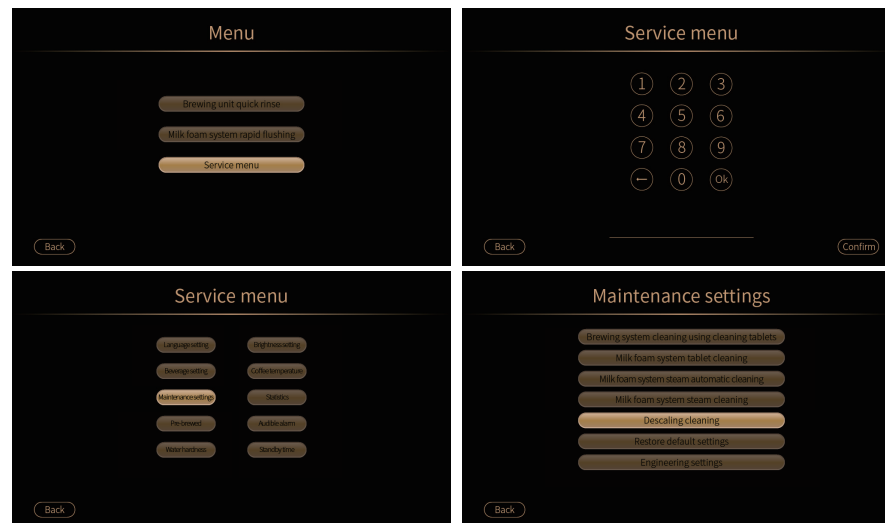

- 1.Press the "☰" icon in the upper right corner of the touch screen. Press "Service Menu", enter password to enter the menu set up program, select "Maintenance Setting" menu to enter the program and select "Descaling Cleaning".

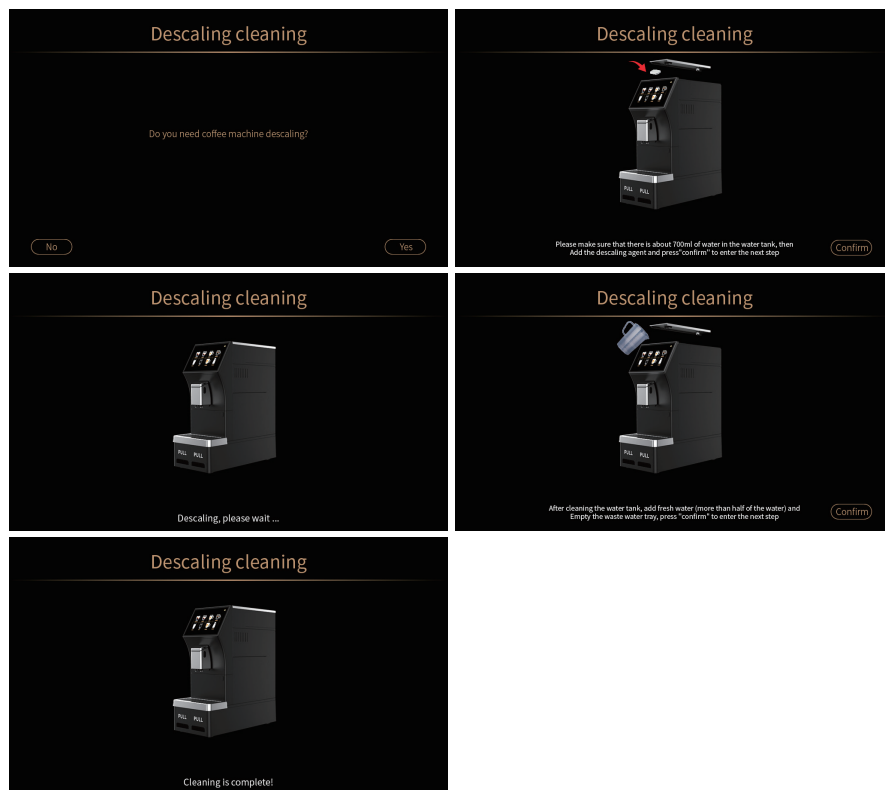

2. "Do you need coffee machine descaling?" press "yes" (as shown in the picture).

3. At this time, the screen displays the words " Please make sure that there is about 700ml of water in the water tank, then add descaling agent and press "Confirm" enter the next step .

4. Empty the water tank, put descaling agent and add 700ml of water, then put it back into the machine.

5. Press the confirm button to start descaling

6. The descaling process automatically carries out a series of rinses and pauses to ensure that the residual scale inside the machine is completely rinsed and dried. This descaling cycle lasts about 15 minutes. During the descaling process, when the display displays "Empty waste water tank", please empty it and put it back in the machine.

7. When the display shows the words ',Clean the water tank, and add water (above half of the tank), then press "confirm" key to proceed to the next step', it means you can clean the machine by fresh water.

8. Take out the water tank, fill it with water (above half of the water tank) and install it back into the machine.

9. Press the confirm key to start rinsing. Hot water will begin to flow out of the coffee outlet. The cleaning process with last about 10 minutes. When the screen displays "the Outlet Water-containing Plate is Full", please empty the Outlet Water-containing Plate and then install back to the machine.

10. After cleaning, pour clean water into the water tank and put it back into the machine.

## Tablet Cleaning of Brewing System

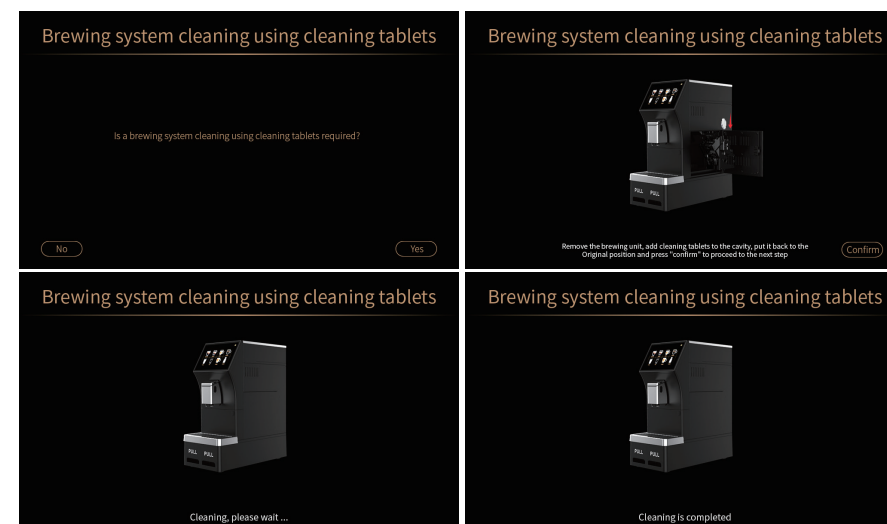

The process of cleaning the brewing system with tablet:

1. Press the icon in the upper right corner of the touch screen to enter the menu set up program. Press "Service Menu", enter the password and confirm. Press "Service Menu -Maintenance-Tablet Cleaning of Brewing Unit System"
2. "Is a brewing system cleaning using cleaning tablets required?" press "yes" (as shown in the figure).
3. Then the screen will display "Remove the Brewing Unit Core and add cleaning tablet, then put back to the original position, press "confirm" to proceed to the next step."
4. Empty the water in the water tank, press the brewing unit door lock button, open the brewing unit door to take out the brewing unit core, put a piece of brewing unit system cleaning tablet in the brewing cavity (as shown in the figure), then put the core back to its original position, close the brewing door, add half tank of the water and put it into the machine.
5. Press the OK icon to start descaling, the outlet water comes out from the coffee outlet. Cleaning program shall rinse and stop automatically for sometimes to ensure the residues in the machine is fully cleaned. This process will last about 10mins.
6. At this time, the screen will display the Outlet Water-containing Plate is Full, please empty the Outlet Water-containing Plate and then install it back to the machine.
7. After cleaning, pour clean water into the water tank and put it back into the machine.

## Tablet Cleaning of Milk Foam System

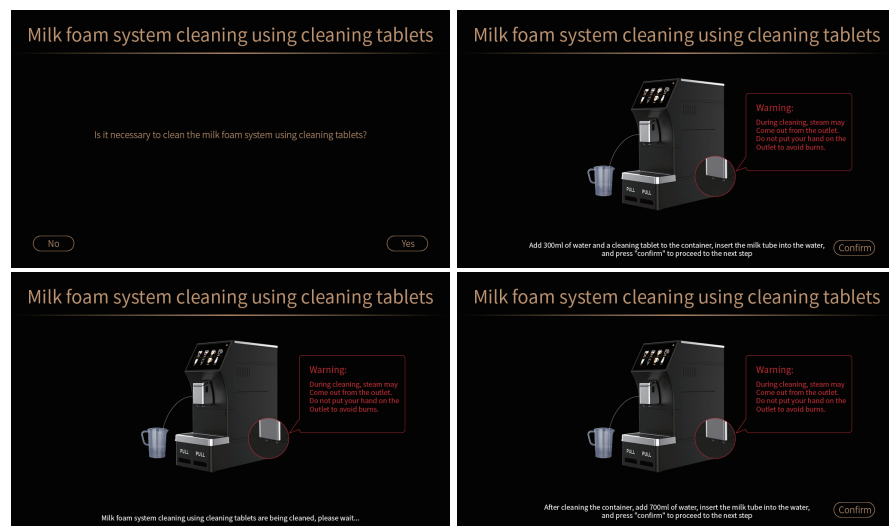

The Cleaning process of milk foam system with tablet:

1. Press the "≡" icon in the upper right corner of the touch screen to enter the menu set up program. Press "Service Menu", enter the password and confirm. Press Service Menu -Maintenance- Milk Froth System Cleaning with Tablet to enter into the program of Milk Froth System Cleaning with Tablet.
2. "Is it necessary to clean the milk foam system using cleaning tablets?" press "yes" (as shown in the figure).
3. Add 300ml water and a cleaning tablet to the container, insert the milk tube into the water, and adjust the knob to the CLEAN position, then press "confirm" to proceed to the next step (as shown in the figure).
4. The milk froth system is under tablet cleaning, please wait for a moment (as shown in the figure).
5. After cleaning the container, add 700ml clear water and put the milk tube into the water. Adjust the knob to the clean position, and press "confirm" to proceed to the next step (as shown in the figure).
6. The system will be under cleaning until the cleaning process is finished.

### Danger of Scalds!

During cleaning, steam may be released from the outlet. It is forbidden to put your hand on the outlet to avoid scalding.

## Milk Foam System Cleaning

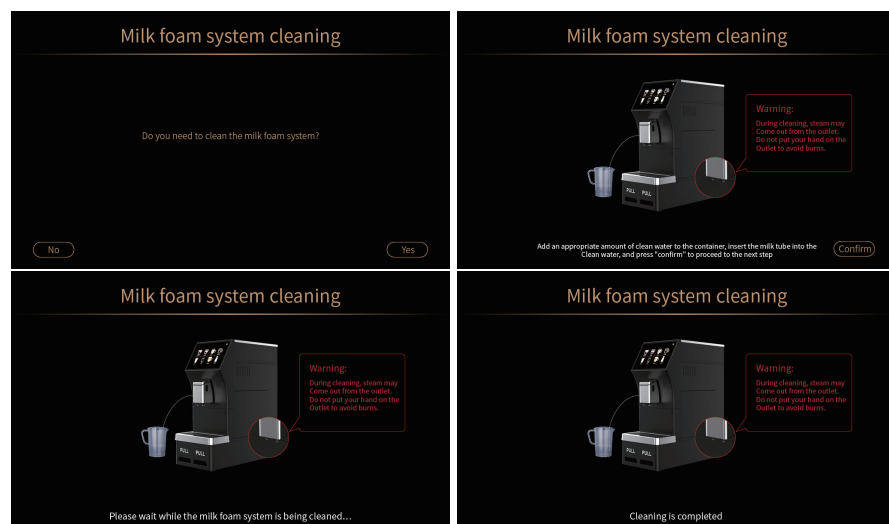

The cleaning process of milk foam system:

1. Press the "≡" icon in the upper right corner of the touch screen to enter the menu set up program. Press "Service Menu", enter the password and confirm. Press "Service Menu → Maintenance settings → Milk foam system steam cleaning" to enter into "Milk foam system steam cleaning".
2. "Do you need to clean the milk foam system?" press "yes" (as shown in the figure).
3. Add some water to the container and put the milk tube into the water. and press "confirm" to proceed to the next step (as shown in the figure).
4. The Milk Foam System is under cleaning, please wait a moment (as shown in the figure).
5. The system will be under cleaning until the cleaning process is finished.

## Milk Foam System Automatic Flushing Setup

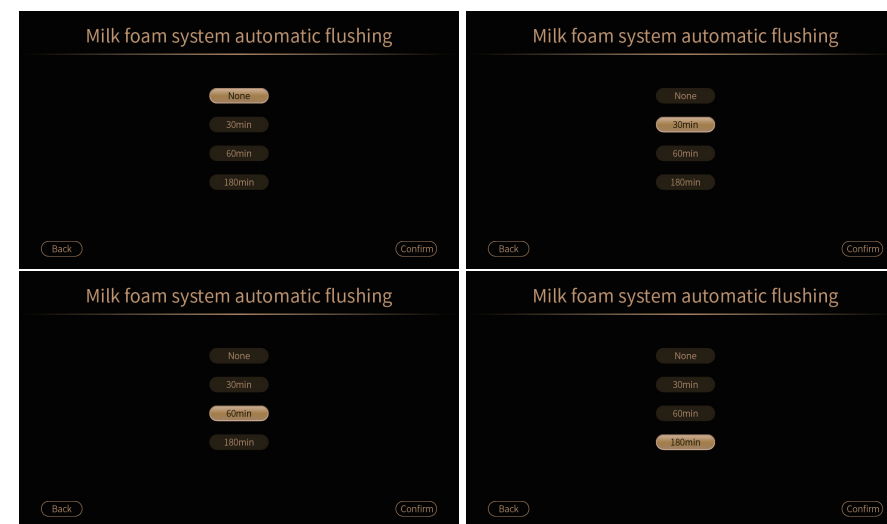

The process of Automatic cleaning of milk foam system setup:

1. Press the "≡" icon in the upper right corner of the touch screen to enter the menu set up program. Press "Service Menu", enter the password and confirm. Press "Service Menu → Maintenance settings → Milk foam system steam automatic flushing" to enter into "Milk foam system steam automatic flushing" setup menu.
2. Select the required options according to the user's requirements, and press the confirm key to complete the settings.

## Milk Foam System Rapid Flushing

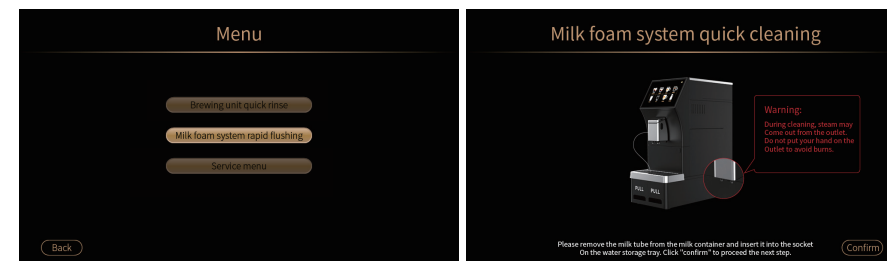



The rapid flushing process of milk foam system:

1. Press the "≡" icon in the upper right corner of the touch screen to enter the menu setup program. Press "Milk foam system rapid flushing" to enter the program of "Milk foam system rapid flushing".
2. Please insert the milk tube into the jack on the waste pan cover, press "Confirm" Key to proceed to the next step, (as the figure shows).
3. The foam system is under rinsing, please wait a moment... (as the figure shows)
4. Rinsing, until the rinsing process is completed.

## Brewing Unit Quick Rinse

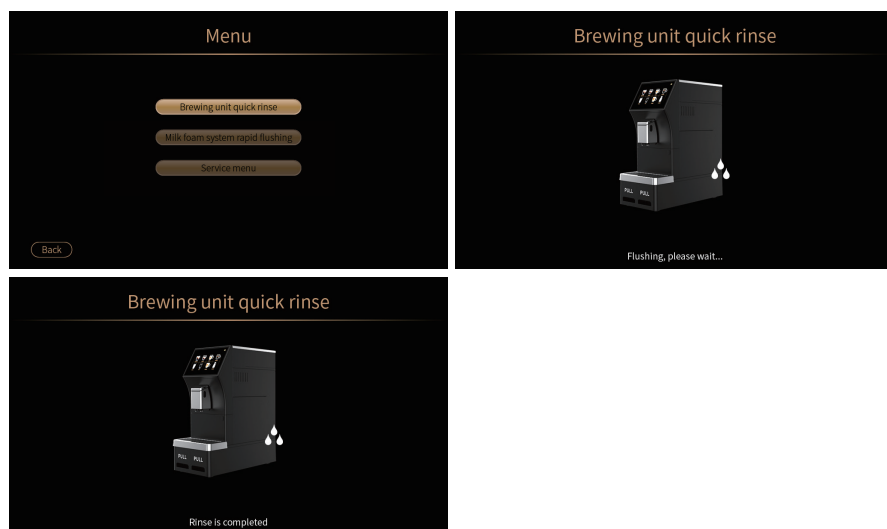

The Quick Rinse Process of Brewing Unit:



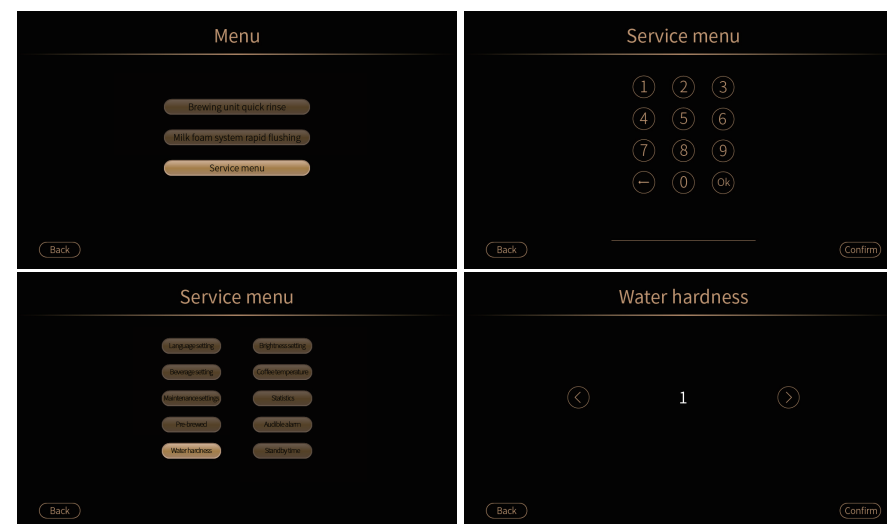

1. Press the "≡" icon in the upper right corner of the touch screen to enter the menu setup program. Press "Brewing unit quick rinse" to enter the program of "Brewing unit quick rinse"
2. The Brewing Unit is under rinsing, please wait a moment... (as the figure shows)
3. Rinsing, until the rinsing process is completed





## Setting of Water Hardness





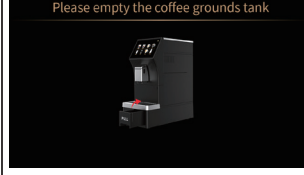
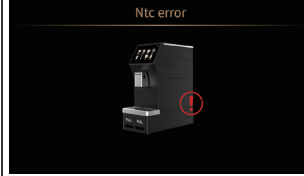

1. Press the "≡" icon in the upper right corner of the touch screen to enter the menu set up program. Press "Service Menu", enter the password and confirm. Press "Service Menu" to setup the program, then select "water hardness" menu.
2. Press "<" and ">" icons to select the hardness of the water (as shown in the figure).
3. Press the confirm key to confirm the setting.
4. Press the "Return" icon to exit the menu program, then the new water hardness setting is completed.

## Prompt Message

Prompt Message	Possible Reasons	Solutions
	After finishing cleaning, the outlet water containing plate is not put into the machine	To put the outlet water containing plate back to the machine
	After finishing cleaning, the brewing unit core is not put into the machine	As described in the section of "Cleaning of Brewing unit core", to put the brewing unit core back to the machine
	No placement or no water in the water tank	To put the water tank in the correct place and top it up
	Coffee bean shortage	Add coffee beans to the bean tank

Prompt Message	Possible Reasons	Solutions
	Brewing door open	Close the brewing door
	After finishing cleaning, the coffee grounds tank is not put back to the machine	To put the coffee grounds tank back to the machine
	Full of coffee grounds	Clean out the coffee grounds tank and return it to the machine
	Possible NTC false positive	Turn off the machine, wait 30 minutes, and turn it on again
	Transmission system anomaly	<ol style="list-style-type: none"> <li>1. Open the brewing door, take out the brewing core, and check whether there is foreign matter entering, causing the brewing core to stick.</li> <li>2. After turning off the main power supply, restart the machine.</li> </ol>

Prompt Message	Possible Reasons	Solutions
 <p>Grinding system error</p>	Grinding System Error	Open the coffee bean tank cover to check if there's hard object inside
 <p>Pipe blockage</p>	Pipe blockage	<ol style="list-style-type: none"> <li>1.Adjust the grinding system to thicker coffee powder</li> <li>2.Clean the brewing unit system</li> <li>3.When the "OK" function button flashes on the touch panel, please press it and wait for a few minutes to solve the problem</li> </ol>
 <p>Coffee boiler power off</p>	Coffee Boiler Power Off	Turn off the machine, to wait a few minutes, then turn on the machine again
 <p>Steam boiler power off</p>	Steam Boiler Power Off	Turn off the machine to wait minute, then turn on again to check.

## General Troubleshooting

The following table is some General Troubleshootings. If the problems are not solved based on the methods, please contact the after-sale service center.

Prompt Message	Possible Reasons	Solutions
The coffee doesn't flow from the coffee machine outlet, but from the surrounding area of the door the coffee machine.	The coffee outlet blocked by the dry coffee residues	To use the toothpick, the sponge or the hard brush to clean the coffee outlet
The fast flowing speed of the coffee	Thickly ground coffee bean	When the coffee grinder is working, to rotate the adjusting button with one square in a counter-clockwise direction. Do not rotate too much to prevent that when you make two cups of coffee, the coffee will flow drop by drop.
The thing that flows from the coffee outlet is water, not coffee	The blocking of the feeding pipe of the coffee powder	As described in the section of "Cleaning of Feeding Pipe of Coffee Powder", to use the cleaning brush to clean the feeding pipe of coffee powder
Water tank shortage	There is no water in the tank or no water tank is installed	Fill the tank with pure water and return it to the machine
The waste tank is full	The waste residue box is full of coffee grounds	Remove the waste residue box and clean the coffee grounds inside, and reinstall the machine
The wastewater tank is full	The waste water tank is full	Remove the waste water tank and clean the waste water inside it and reinstall it into the machine
Milk foam is too large or there is milk gushing from the outlet	The milk is not cold enough or not whole milk	Use the whole milk frozen in the refrigerator ( at about 5 ℃ ). If the results are not satisfactory, please replace the milk brand.
	The foam system is blocked	Perform foam system cleaning, refer to (Foam System Cleaning section)



## Waste Treatment

The used machine should not be disposed of as ordinary household appliances. Please treat the used coffee machine in an environment friendly way as it contains valuable materials that can be recycled. If electrical waste is buried by mistake, harmful substances will infiltrate into the ground to affect the underground water quality, which may cause damage to the food nutrition supply chain, thus dispose of old machines through a suitable collection system.

Note: Coffee machine performance parameters, functions are subject to change without prior notice! Please refer to the actual product!

## Reminder

1 .Before leaving the factory, the coffee machine will be tested so it is normal to have a little ground coffee or water in the machine. All the above are normal phenomena and not belong to quality problems.

2.Please take good care of the packing box, which makes it convenient to return the machine to the factory for maintenance or other transfer, to avoid damage during transportation.