

BIOBASE

Laboratory Refrigerator BPR-5V628/968 User Manual

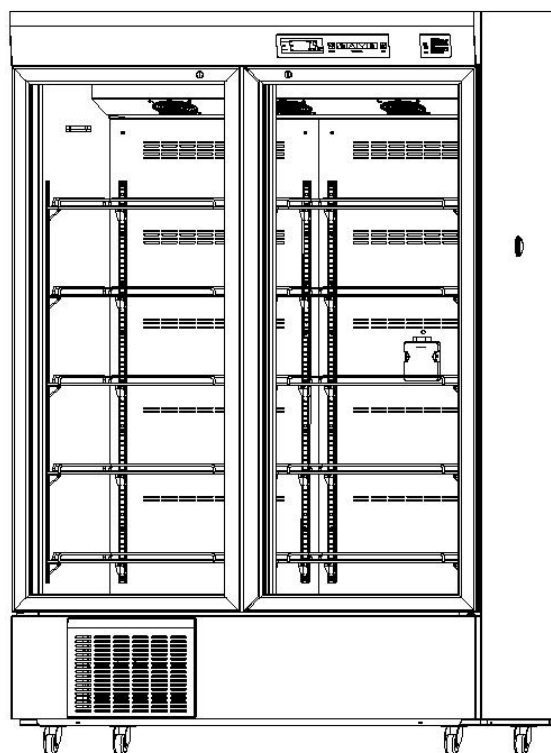

BIOBASE GROUP

Version 2022.05

Statement

Thank you for choosing and using the product of BIOBASE. For your safe and convenient use and reasonable maintenance of the product, please read the operation instruction carefully and keep it properly for reference.

For damages of any instrument due to the fact that the user does not use the product according to the instrument operating environment declared in the handbook or injuries due to the fact that individual does not operate the product according to safety instructions, BIOBASE has no obligations and responsibilities to be in charge of them.

The user must accomplish the following three points when using the product:

1. Always use protective devices correctly (including clothes, gloves, goggles, etc.);
2. Always adopt good health habits and operate strictly according to the product instruction;
3. Everyone is obliged to be in charge of one' own safety.

Due to the fast product update of BIOBASE, there may be differences between function of the product you bought and the function mentioned in the instruction, please in kind prevail.

Safety Instruction:

- Please read the handbook carefully when using the machine for the first time.
- The Laboratory refrigerator can only be operated by trained and authorized personnel.
- The maintenance of the equipment can only be accomplished by BIOBASE or agents authorized by BIOBASE.
- if operator runs into conditions not mentioned in the instruction, please contact BIOBASE or agents authorized by BIOBASE for inquiring correct processing method.
- please use accessories provided by BIOBASE. if user uses other accessories, BIOBASE will not take charge of generated negative effects. however, the user can apply to BIOBASE to test and verify that whether the accessories accord with the requirements of BIOBASE.
- It is necessary to inspect and maintain the Laboratory refrigerator at specified time intervals.
- The Laboratory refrigerator is strictly prohibited to store living things or other goods which have strict temperature requirement and are unsuited for storage at constant temperature.
- The Laboratory refrigerator realizes refrigeration through the heat dissipation of the back surface (condenser). In order to ensure normal operation and ventilation and heat dissipation, the back and the left and right sides of the refrigerator body should be at least 30cm away from the wall and no barriers are allowed to block the air inlet and the air outlet.
- In case of machine fault or power failure, the temperature in the Laboratory refrigerator will rise. If the machine cannot be repaired in short period, please take out the stored goods and transfer them to other place where accords with the storing temperature to avoid damages.

Content

Statement	1
Content	2
1. Diagram and Introduction of Product	3
2. Preparation and Attention before Use	4
3. Instructions	5
3.1 First use	5
3.2 Temperature regulation	5
3.2.1 Key function	5
3.2.2 Parameter setting method	6
3.2.3 Error display	6
4. Routine Maintenance	8
4.1 Clean of incubator	8
4.2 Defrost	8
4.3 Care and maintenance	8
5. Clearing of Fault and Maintenance Service	9
6. Main Performance Index	10
6.1 Main technical parameters	10
6.2 Wiring Diagram	10
Packing list	11
7. Warranty	12

1. Diagram and Introduction of Product

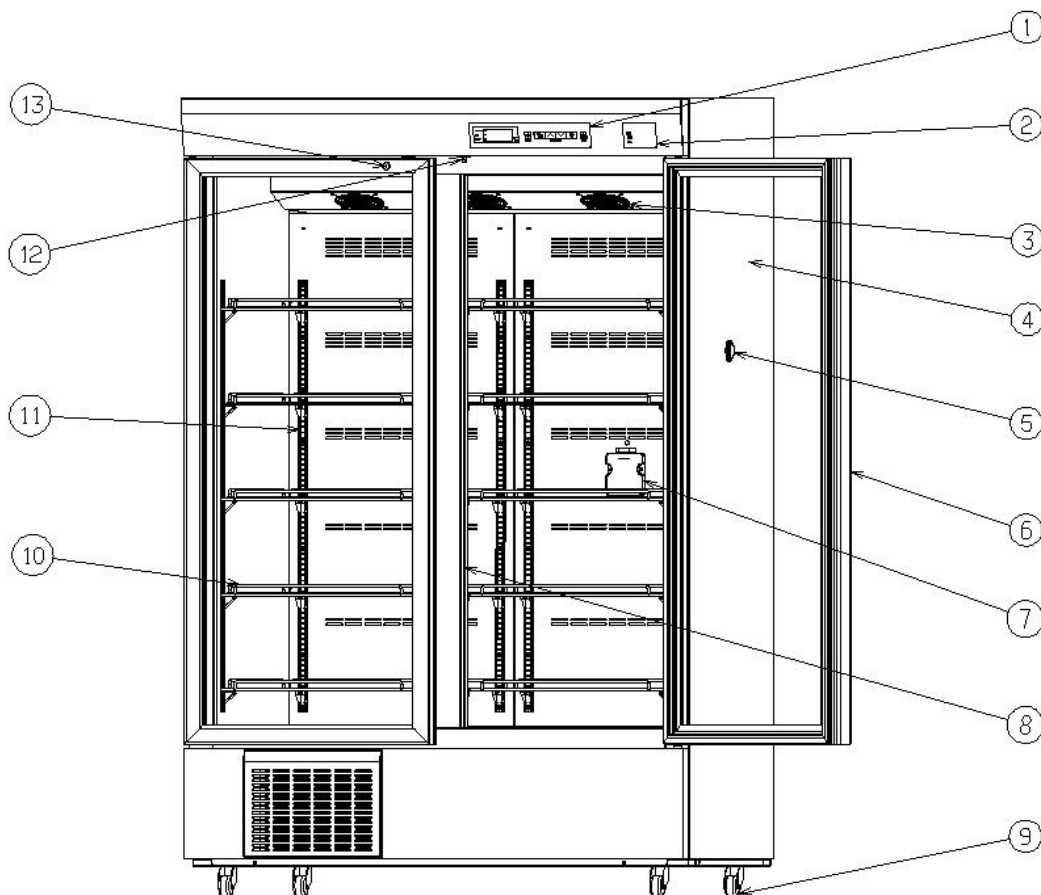

DiagramI: Structural diagram

- | | | | |
|---------------|-----------|------------------------------|-----------------|
| 1- Thermostat | 2- USB | 3-Fan | 4- Cabinet |
| 5- Test hole | 6- Door | 7- Temperature sensitive box | 8- Stand column |
| 9- Caster | 10- Shelf | 11- Shelf hanger | 12-Door switch |
| 13- Lock | | | |

LED lamp is located in the back of 8-stand column.

Due to the improvement and various models of products, the actual product may be different from the diagram, please in kind prevail !

Laboratory refrigerator series products are applied to places needing storage at constant temperature, such as hospitals, epidemic prevention stations, blood banks, scientific research institutions, colleges and universities, biological pharmacies, genetic engineering, entrepreneurs, etc. The storing temperature in the body can be regulated by the temperature button on the control panel. The application is convenient and the performance is reliable.

2. Preparation and Attention before Use

- Transport: the refrigerator should be uplifted from the bottom and carried and put down lightly. The inclined plane should be no larger than 45 degrees.
- Do not hold the door or the lining port as stressed member.
- Dismantle all package components (including protection foam in the refrigerator body).
- Please check accessories and data according to the packing list.
- Please clean the product before use.
- Operating environment requirements:
 - a) For indoor use only;
 - b) The mounting surface must be fixed, horizontal and incombustible and be able to bear weight during the operation of the Laboratory refrigerator;
 - c) To be placed away from direct glare of sunshine and heat and the environmental temperature should be not higher than 32°C.
 - d) Space of above 30cm is required to be left around the Laboratory refrigerator for ventilation and heat dissipation;
 - e) Not allowed to be placed in the environment under 0°C ;
 - f) Not allowed to be placed at places with heavy moisture or easy-splashing water.
- On flat ground, the Laboratory refrigerator can be directly pushed to move.

! Notes: please note that do not let the power line be damaged by trundles when pushing the Laboratory refrigerator.

! Notes: be sure to take off the packaging pedestal on the bottom of the Laboratory refrigerator.

! Notes: Do not put goods into the Laboratory refrigerator which is just plugged in. Let the empty body run for a while (about 12 hours) and then put the goods to be refrigerated into the refrigerator.

Normal operating condition of the equipment:

- a) Environmental temperature: 10°C ~32°C ;
- b) Relative humidity: ≤80% ;
- c) There is no strong sharp pounding and corrosive gas around;
- d) There are no effects of direct radiation of sunshine and other cold and heat sources.

Working system of the Laboratory refrigerator: intermittent running

Safety precautions

- Supply voltage: the equipment needs 220V/50Hz alternating current power supply. If the service voltage is lower than 187V or higher than 242V, it is necessary to add a proper automatic voltage regulator to be used cooperatively;
- When the Laboratory refrigerator is used, the power supply is required to be equipped with a lower voltage air circuit breaker and a leakage protection device;
- It is necessary to use a dedicated independent socket which is grounded reliably. The length of the power line cannot be lengthened at randomly. If it really needs to be lengthened, be sure to use a cooper core conductor which is larger than 2.5mm². And the cross area of the copper core

- conductor which is in the wall and connected with the power socket must be above 4mm²;
- Inflammable and explosive dangerous goods and goods of acid and alkali etc. with strong corrosiveness are not allowed to be put into the Laboratory refrigerator;
- Keys should be kept properly to avoid accidents that will happen if children get the key to open the door;
- The zero line (N end) of the socket cannot be connected with the ground lead (B end). Otherwise, the housing of the Laboratory refrigerator may be electrified and electric shock accidents may be caused;
- The power line cannot be bundled up, pressed under weight and next to heat sources of compressor, etc.

3. Instructions

3.1 First use

- After being unpacked, the Laboratory refrigerator should be placed well to according to the service environment requirement;
- Although the refrigerator has been cleaned inside when leaving factory, it is advised to scrub the Laboratory refrigerator with warm water added with a little neutral detergent and then scrub it with clean water and wipe it up (electrical system cannot be cleaned but scrubbed with dry cloth);
- Set the temperature controller of the Laboratory refrigerator at 5℃ and turn on the power. After 3 minutes, the compressor is started. After 30 minutes, the temperature inside the Laboratory refrigerator decreases obviously. It means the refrigerating system is operating smoothly and the machine test is finished;
- For first use, it is advised to put the goods to be stored in the refrigerator after the inside temperature falls to the operating temperature. If there are too much goods to be stored, it is advised to store separately for three times. When the inside temperature of the refrigerator falls to the set temperature after the storage of the last time, store the goods for the second time. Storing too much goods at one time may cause that the refrigerator cannot fall to the set temperature for a long time, thereby causing damages of goods;
- In order to save electrical energy, please try to reduce door-opening frequency and open time.

3.2 Temperature regulation

3.2.1 Key function

The electric temperature controller is installed on the control panel of the Laboratory refrigerator. When power is on, the digital display screen can display the actual temperature inside the refrigerator. The control panel of the temperature controller is illustrated by the following diagram:

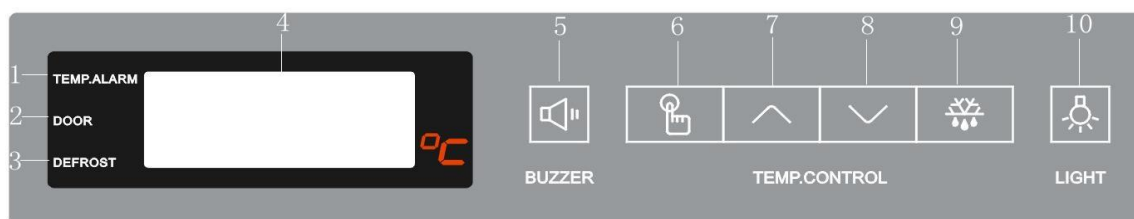

1-High temperature warning mark 2-Door opening warning mark

3-Battery status mark 4-Inside temperature display

5-Mute 6-Set 7-Up-regulation

8-Down-regulation 9-Defrost 10-On-off key of light

It is recommended not to adjust the setting temperature at random when it is in normal use. Otherwise, the high temperature (AH) alarm or the constant temperature (AL) alarm will be stimulated, during which, please adjust the high, constant temperature alarm (AH, AL) values at the same time.





Mute key: when the alarm sound prompt needs to be canceled, we can cancel the voice prompt by pressing the mute key, but the alarm indicator and the alarm code will always show until the alarm state is released.

USB: Insert the USB flash drive, the uP symbol on the display is lit, indicating that the data starts to be stored; when the End symbol on the display is lit, indicating that the data storage is completed, and the USB flash drive can be taken out. The format for the file exported is csv, which can be read by Excel. The data storage capacity is 8000, the data will be covered after overrun.

Defrost key: the function is not suitable for this series of products.

3.2.2 Parameter setting method

When the power of the Laboratory refrigerator is on, the display screen displays the inside current temperature value. If the set temperature has to be readjusted, for example, the original set temperature is 2 °C which now has to be adjusted to 5 °C, please operate according to the following steps:

Serial No.	Keys Operation	Display
1		Displays the inside temperature
2	Press the Set key  for 3 seconds	Displays that the initial set value is 2 °C and twinkles
3	Press the Up-regulation key 	Figure increases
4	Press the Down-regulation key 	Figure decreases
5		Figure is 5 °C
6	Press the Set key  for 3 seconds	Saves the user settings and displays the inside temperature

Notes: If there is indeed parameter change requirement, please contact the after-sale and distributors of BIOBASE for setting.

Notes: When working normally, simultaneously press the down-regulation key and Defrost key for 5 seconds, enter the page of setting time parameter value, the default page displays t (min). The corresponding parameters of H (hour), D (day), M (month), and Y (year) were displayed respectively after press the up-regulation key. Select the parameters that needed to be adjusted, press the set key and the digital tube flickers, adjust the parameters by pressing the up-regulation key or down-regulation key, then press the set key to save the current parameter value. In the process, if the down-regulation key and Defrost key are pressed at the same time, the temperature display interface is restored.

3.2.3 Error display

When faults of the refrigerator temperature display probe including short circuit, open circuit, malfunction and incorrect connection appear, “E0” is displayed. When faults of the refrigerator

temperature control probe including short circuit, open circuit, malfunction and incorrect connection appear, “E1” is displayed. At the same time, the buzzer of the temperature controller will give out alarm and the display screen displays corresponding alarm parameters (E0、 E1).

After the power is switched off, the control function of the controller fails and the back-up source is used for displaying. If the back-up source is charged for more than 10 hours, the power failure symbol “Pd”, the current inside temperature and the alarm display alternatively for one time and then display again after 30 seconds’ stop for cycle operation. After 8 hours, the nixie tube stops displaying. The high temperature alarm mark light will twinkle continuously until the electric quantity of the back-up source is used up. The inside temperature can be continuously displayed during the power failure. Please pay attention to this and take relevant measures to avoid damages.

Suggest: If you judge that the temperature sensing probe goes wrong, you should cut off the power and first check whether the connecting wire of the temperature sensing probe is loose. Please contact professional after-sale personnel or distributor of BIOBASE for processing.

Tips: if internal code appears when user regulates the temperature controller, the user should wait for 1 minute and then operate it till the inside temperature is displayed to avoid fault of the Laboratory refrigerator caused by the change of the control parameter.

When the Laboratory refrigerator stalls temporarily due to power failure or other faults, the inside temperature of the Laboratory refrigerator will rise from 5°C to 15°C within 1 hour. If power cannot be supplied in short time, the user should consider taking out the stored goods and putting them into other normal Laboratory refrigerators for storing to avoid losses caused by the damages of the stored goods.

Before putting goods into the Laboratory refrigerator to be stored, the user should confirm in advance that whether inside temperature of the Laboratory refrigerator is in accordance with the set temperature for storing to avoid losses caused by goods damages due to the improper temperature.

Due to the refrigeration inertia, the Laboratory refrigerator cannot be kept at constant temperature. And there is certain up and down difference between the inside temperature and the set temperature. The inside temperature varies with the change of the service environment and the set temperature. It belongs to normal phenomenon.

4. Routine Maintenance

In routine maintenance, in order to prevent electric shock or personnel injuries, be sure to cut off the power before repairing or maintaining the equipment and do not inhale drugs or particulate matters surrounding the equipment when maintaining the equipment. It is necessary to dry wet gloves to protect your hands. Otherwise, your hands may be cut by edges or corners of the refrigerator body.

4.1 Clean of incubator

- The Laboratory refrigerator should be cleaned once every month. Regular cleaning may keep the appearance of the incubator new;
- Use dry cloth to wipe off a small amount of dust on the housing, the inner chamber and all accessories of the Laboratory refrigerator. If the Laboratory refrigerator is very dirty, it is advised to use neutral detergent for cleaning;
- After cleaning, use cloth which has been soaked in clean water to wipe off the detergent;
- Do not pour water on the housing or in the preserve room of the Laboratory refrigerator. Otherwise, the electrical insulation may be damaged, thereby causing faults.
- During the rainy season, vapors may be easily condensed on the surface of the glass door of the refrigerator. In serious condition, water may drip. Please use dry cloth to wipe it dry in due time. Normal use will not be affected.

4.2 Defrost

The Laboratory refrigerator belongs to air cooling frostless refrigerator which needs no defrosting. In summer with high environment humidity, condensation may appear on the buccal frame of the Laboratory refrigerator. This is normal. It is advised to wipe it dry with dry cloth.

4.3 Care and maintenance

- No heavy things are allowed to be placed on the door or the header of the Laboratory refrigerator to avoid deformation of the door body or the header caused by the press.
- The Laboratory refrigerator should be cleaned and maintained every once in a while.
- Use warm wet soft cloth to wipe the inner and outer surfaces of the Laboratory refrigerator.
- When serious dirt appears, use neutral detergent for washing tableware to wipe and then use cleaned soft cloth to wipe out the water spots.
- Once starting the Laboratory refrigerator, you'd better keep it running continuously.

! Notes: be sure not to sprinkle water directly on the Laboratory refrigerator to avoid performance reduction and metal rust of electrical components. Be sure not to clean the Laboratory refrigerator with hot water and corrosive detergent or organic solvent. Also do not clean the Laboratory refrigerator with scrubbing brush and wire brush. Children are not allowed to play games with the Laboratory refrigerator.

5. Clearing of Fault and Maintenance Service

Some abnormal conditions of the Laboratory refrigerator are caused by misuse. Before you commit maintenance, please compare with the following table for self inspection and exclusion.

Problems	Reasons and Solving Measures
Laboratory refrigerator does not work	<ul style="list-style-type: none"> ·If the power socket has electricity? ·If the power socket is plugged or loosened? ·If the power fuse is disconnected? ·If the supply voltage is too low or too high?
Compressor breaks down	<ul style="list-style-type: none"> ·If the temperature setting is right?
Temperature goes on decreasing after reaching to the set value	<ul style="list-style-type: none"> ·If the temperature setting is right?
Temperature cannot reach the set value	<ul style="list-style-type: none"> ·If the fan stops running? ·If the door is not closed tight or opened too frequently? ·If too many goods are put in at one time and if the air channel is blocked off? ·If the environment temperature is too high?
Too much noise	<ul style="list-style-type: none"> ·If the refrigerator body is placed at the flat ground? ·If the refrigerator body touches the wall? ·If the incubator immediately enters operating state after being started?

If you cannot judge the fault cause or debug, please contact the local or nearby appointed service center according to the instruction of the warranty certificate (standard accessory) and tell use your name, address, phone number, type of the Laboratory refrigerator, purchase time, fault phenomenon, etc. Professional engineer will offer warmhearted service to you.

6. Main Performance Index

6.1 Main technical parameters

Model	Temp	Volume	Power supply	Refrigerant	Dimension
BPR-5V628	2~8°C	628L	220V, 50Hz	R134a	1220×630×1885
BPR-5V968	2~8°C	968L	220V, 50Hz	R134a	1220×860×1885

6.2 Wiring

Diagram

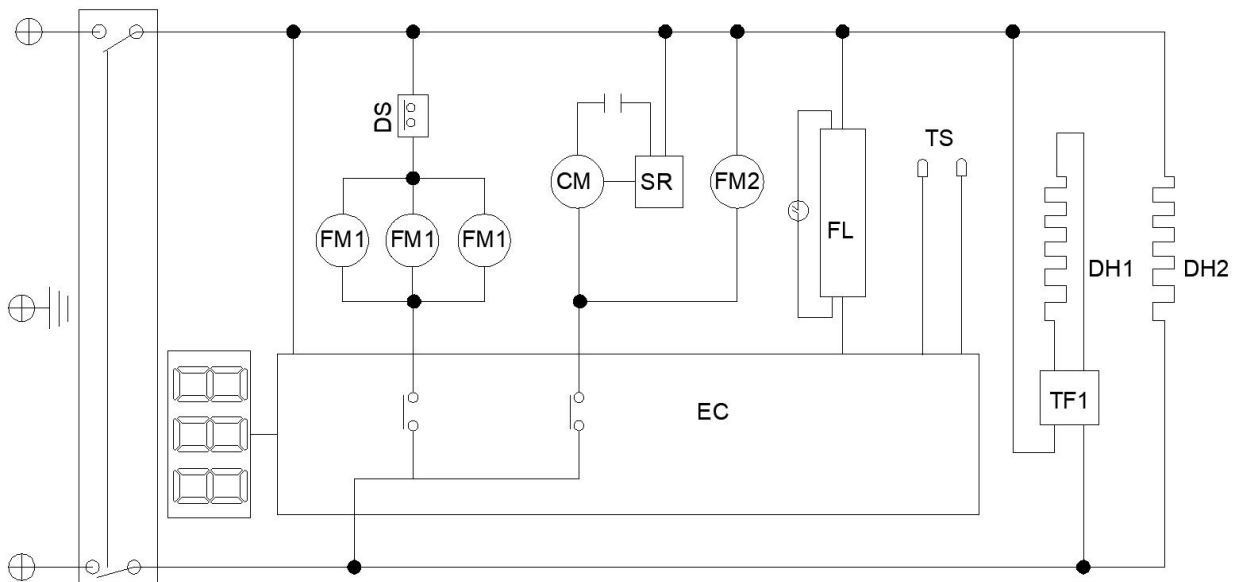

FL= Fluorescent Lamp

CM= Compressor

TF1=Adapter

DH1= Door Heating Film

FM1= Evaporative Fan

SR= Starting relay

DS= Door Switch

DH2=Middle prop Heating

FM2= Condensing Fan

EC= Control Circuit Panel

TS= Temperature Probe

Packing list

Model	BPR-5V628	BPR-5V968
User Instruction	1	1
Key	4	4
Shelf	10	10
Snap	40	40
Fuse (10A)	2	2
Power Cord	1	1

7. Warranty

- ◆ If the instrument and equipment during the warranty period fails or damages due to improper use by the user, our company shall not bear the warranty obligation.
 - ◆ After the warranty period, our company is also responsible for the maintenance, but the corresponding maintenance fee will be charged.
 - ◆ For the production date, please refer to the product label.
 - ◆ We can provide the drawings and some necessary technical data for the maintenance units and maintenance personnel trained and approved by our company.
1. From the date of purchase, the user can enjoy one-year free warranty for the whole machine and three-year warranty for the compressor (man-made damage is not within the scope of warranty), and the purchase time is subject to the valid purchase documents.
 2. The following situations are not within the scope of warranty, only maintenance services are provided, but corresponding cost are charged.
 - (1) All damages caused by human factors, including damages caused by using in abnormal working environment, not following the user manual and improper operation, etc.
 - (2) If the user disassembles, repairs or refits the machine without permission, or the device is not repaired by the authorized unit of our company, or there is no warranty card or valid document.
 - (3) Damage caused by improper transportation or other irresistible factors (such as flood, fire, lightning, earthquake, etc.) after purchase.

JINAN BIOBASE BIOTECH CO., LTD.

ADDRESS: OLABO Intelligent Manufacturing Industrial Park, Ancheng Town, Pingyin County,
Jinan City, Shandong

Tel: +86-531-81307661

Inquiry: export@biobase.com

Complaints: customer_support@biobase.cc

After-sales service: service_sd@biobase.cc; service_ivd@biobase.cc

Web: www.biobase.cc/www.meihuatrade.com / www.biobase.com

